

# Historical prospective of OFC

The first instances of glass being drawn into fibers date back to the Roman times, however it was not until the 1790's that a pair of French brothers named Chappe, invented the first "optical telegraph". This primitive system was made up of towers outfitted with a series of lights that operators could use to relay messages back and forth.

Throughout the next century, historical developments would be made in the field of optical science.

## A Brief History of Fiber Optics

Starting in the 1840's, physicists Daniel Collodon and Jacques Babinet demonstrated that light could be directed along water jets for nighttime fountain displays. Later, in 1854, British physicist John Tyndall proved that light could travel through a curved stream of water. Using a tank of water with a pipe that ran out of one side, Babinet then shone a light into the tank, into the stream of water. An arc of light followed the water as it fell.

An optical telephone system was patented in 1880 by Alexander Graham Bell. Bell's "photophone" never panned out and his earlier invention the telephone proved much more successful. Later that same year, William Walter tried his hand at inventing a series of light pipes lined with a highly reflective coating that illuminated homes by utilizing light from an electric arc lamp located in the basement of the home. The light was then directed through the house with a series of pipes.

Bent glass rods were used by physicians Roth and Reuss in Vienna to illuminate body cavities in 1888. This was followed by French Engineer Henri Saint-Rene who utilized a series of bent glass rods for guiding light images, an early attempt at television. In 1898, American David Smith patented a dental illuminator that relied on a curved glass rod.

In the 1920's John Logie Baird obtained a patent for using arrays of transparent rods to transmit images for television, while Clarence W. Hansell used the same configuration to create facsimiles. During 1930, Heinrich Lamm successfully transmitted and images through a bundle of fibers. The image was of a light bulb filament. Lamm intended to use this system to look inside the human body, however with the shift in power during World War II, he was forced to abandon his work and seek asylum in America. He made an effort to file a patent but was denied because of Hansell's British Patent.

Danish physicist Holger Moeller, applied for a patent in 1951 for fiber-optic imaging. He proposed coating glass or plastic fibers with a low index material. His patent was denied because of Baird and Hansel's patents. Three years later Abraham Van Heel and Harold H. Hopkins debuted imaging bundles at two different times in the British journal Nature. Later, Van Heel produced a cladded fiber system; it showed a great reduction in signal interference and issues between fibers, like crosstalk. At Columbia University, in 1954, Charles Townes and his colleagues developed 'maser'. Maser stands for "microwave amplification by stimulated emission of radiation".

Not until 1958 was the laser introduced as an efficient source of light. Charles Townes and Arthur Schawlow intended to show that masers could operate in optical and infrared regions. Light is reflected back and forth to generate amplified light, as opposed to excited gas molecules being amplified to generate radio waves, as in the maser. The first continuously operating helium-neon gas laser was invented and tested in 1960. That same year, using a synthetic pink ruby crystal, an operable laser was invented.

Elias Snitzer of American Optical published a 1961 theoretical description of single mode fibers, with a core so small that it could carry light with a single waveguide mode. He was able to demonstrate a laser directed through a thin glass fiber that had implications in medicine, but suffered too great a light loss to have any communication applications.

In 1964, Charles Kao and George Hockham from Standard Communications Laboratory in England published a paper that demonstrated, in theory, how removing impurities from glass fibers could dramatically improve light loss.

It was not until 1970 that scientists at Corning Glass Works created a single mode fiber that had less than a 20dB/km attenuation. This result was achieved by doping silica glass with titanium. Bell Laboratories, along with Morton Panish, Izuo Hayashi and a group from the Physical Institute in Leningrad showcased a semiconductor diode laser that could emit continuous waves at room temperature in 1973.

In the late 1970's and 1980's, telephone companies began to use fiber extensively in their communications networks. In the mid-1980's Sprint founded the first nationwide, 100 percent digital fiber network. A reduction in the cost of long distance systems came in 1986 with the erbium-doped fiber amplifier developed by David Payne of the University of Southampton and Emmanuel Desurvire at Bell Laboratories. The first transatlantic telephone cable went into operation in 1988 utilizing Desurvire's laser amplification technology.

Debating in 1991, Desurvire and Payne demonstrated optical amplifiers that were built into the fiber-optic cable itself. This all optic system could support more than 100 times more information than a cable with electronic amplifiers. Also in 1991, photonic crystal fiber emerged. Guiding light by means of diffraction, this fiber allows power to be carried more efficiently than by conventional fibers.

The TPC - 5, an all-optic fiber cable that uses optical amplifiers was laid across the Pacific Ocean in 1996. The next year Fiber Optic Link Around the Globe or FLAG became the longest single cable network on record and is the base for the next generations of Internet applications.

Today's technology finds fiber optics in many industries, in a variety of applications. Military, medical, telecommunication, data storage, networking, industrial, and broadcast industries have all found ways to utilize this versatile fiber.

## **OPTICAL FIBER COMMUNICATION SYSTEM**

### **How a Fiber Optic Communication Works?**

Unlike copper wire based transmission where the transmission entirely depends on electrical signals passing through the cable, the fiber optics transmission involves transmission of signals in the form of light from one point to the other. Furthermore, a fiber optic communication network consists of transmitting and receiving circuitry, a light source and detector devices like the ones shown in the figure.

When the input data, in the form of electrical signals, is given to the transmitter circuitry, it converts them into light signal with the help of a light source. This source is of LED whose amplitude, frequency and phases must remain stable and free from fluctuation in order to have efficient transmission. The light beam from the source is carried by a fiber optic cable to the destination circuitry wherein the information is transmitted back to the electrical signal by a receiver circuit.

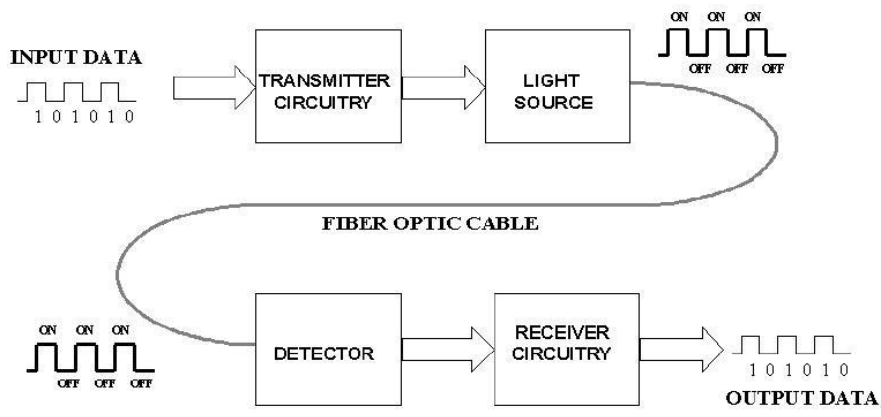

Working of Fiber optic communication

The Receiver circuit consists of a photo detector along with an appropriate electronic circuit, which is capable of measuring magnitude, frequency and phase of the optic field. This type of communication uses the wave lengths near to the infrared band that are just above the visible range. Both LED and Laser can be used as light sources based on the application.

### 3 Basic Elements of a Fiber Optic Communication System

There are three main basic elements of fiber optic communication system. They are

1. Compact Light Source
2. Low loss Optical Fiber
3. Photo Detector

Accessories like connectors, switches, couplers, multiplexing devices, amplifiers and splices are also essential elements in this communication system.

#### 1. Compact Light Source

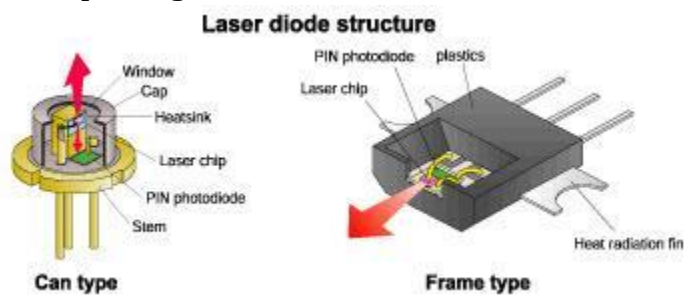

Laser Diodes

Depending on the applications like local area networks and the long haul communication systems, the light source requirements vary. The requirements of the sources include power, speed, spectral line width, noise, ruggedness, cost, temperature, and so on. Two components are used as light sources: light emitting diodes (LED's) and laser diodes.

The light emitting diodes are used for short distances and low data rate applications due to their low bandwidth and power capabilities. Two such LEDs structures include Surface and Edge Emitting Systems. The surface emitting diodes are simple in design and are reliable, but due to its broader line width and modulation frequency limitation edge emitting diode are mostly used. Edge emitting diodes have high power and narrower line width capabilities.

For longer distances and high data rate transmission, Laser Diodes are preferred due to its high power, high speed and narrower spectral line width characteristics. But these are inherently non-linear and more sensitive to temperature variations.

## ADVANTAGES & DISADVANTAGES OF OFC

## Advantages of Fiber Optic Transmission

Optical fibers have largely replaced copper wire communications in core networks in the developed world, because of its advantages over electrical transmission. Here are the main advantages of fiber optic transmission.

**Extremely High Bandwidth:** No other cable-based data transmission medium offers the bandwidth that fiber does. The volume of data that fiber optic cables transmit per unit time is far greater than copper cables. **Longer Distance:** in fiber optic transmission, optical cables are capable of providing low power loss, which enables signals can be transmitted to a longer distance than copper cables. **Resistance to Electromagnetic Interference:** in practical cable deployment, it's inevitable to meet environments like power substations, heating, ventilating and other industrial sources of interference. However, fiber has a very low rate of bit error ( $10 \text{ EXP-13}$ ), as a result of fiber being so resistant to electromagnetic interference. Fiber optic transmission is virtually noise free. **Low Security Risk:** the growth of the fiber optic communication market is mainly driven by increasing awareness about data security concerns and use of the alternative raw material. Data or signals are transmitted via light in fiber optic transmission. Therefore there is no way to detect the data being transmitted by "listening in" to the electromagnetic energy "leaking" through the cable, which ensures the absolute security of information. **Small Size:** fiber optic cable has a very small diameter. For instance, the cable diameter of a single OM3 multimode fiber is about 2mm, which is smaller than that of coaxial copper cable. Small size saves more space in fiber optic transmission.

### Optical Fiber Core Diameter *Relative Size Comparison*

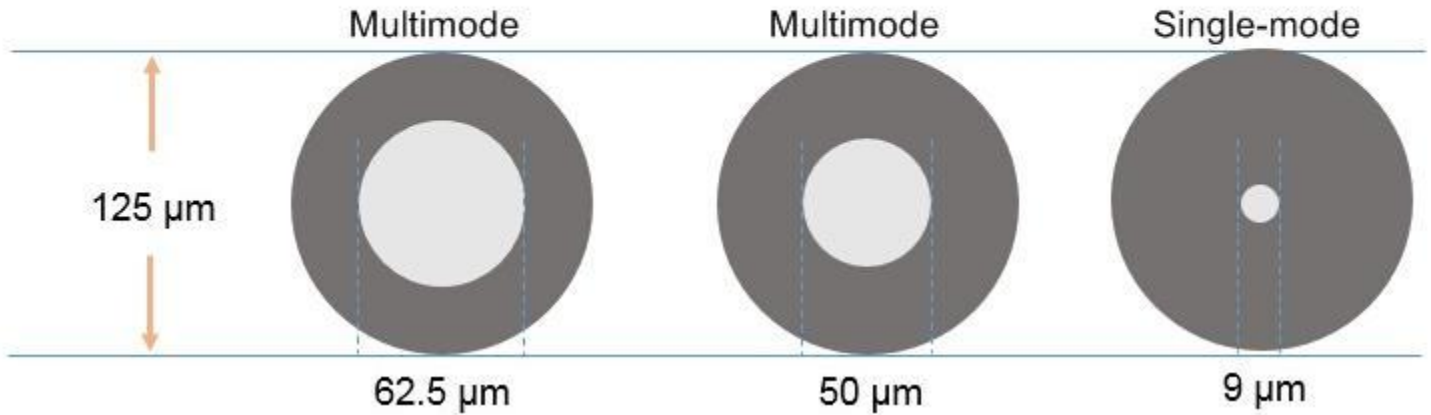

Figure 2: core diameter of fiber optic cable

**Light Weight:** fiber optic cables are made of glass or plastic, and they are thinner than copper cables. These make them lighter and easy to install. **Easy to Accommodate Increasing Bandwidth:** with the use of fiber optic cable, new equipment can be added to existing cable infrastructure. Because optical cable can provide vastly expanded capacity over the originally laid cable. And WDM (wavelength division multiplexing) technology, including CWDM and DWDM, enables fiber cables the ability to accommodate more bandwidth.

## Disadvantages of Fiber Optic Transmission

Though fiber optic transmission brings lots of convenience, its disadvantages also cannot be ignored.

**Fragility:** usually optical fiber cables are made of glass, which lends to they are more fragile than electrical wires. In addition, glass can be affected by various chemicals including hydrogen gas (a problem in underwater cables), making them need more cares when deployed under ground. **Difficult to Install:** it's not easy to splice fiber optic cable. And if you bend them too much, they will break. And fiber cable is highly susceptible to becoming cut or damaged during installation or construction activities. All these make it difficult to install. **Attenuation & Dispersion:** as transmission distance getting longer, light will be attenuated and dispersed, which requires extra optical components like EDFA to be added. **Cost Is Higher Than Copper Cable:** despite the fact that fiber optic installation costs are dropping by as much as 60% a year, installing fiber optic cabling is still relatively higher than copper cables. Because copper cable installation does not need

extra care like fiber cables. However, optical fiber is still moving into the local loop, and through technologies such as FTTx (fiber to the home, premises, etc.) and PONs (passive optical networks), enabling subscriber and end user broadband access.

## APPLICATIONS

Fiber optic cables find many uses in a wide variety of industries and applications. Some uses of fiber optic cables include:

- **Medical**  
Used as light guides, imaging tools and also as lasers for surgeries
- **Defense/Government**  
Used as hydrophones for seismic and SONAR uses, as wiring in aircraft, submarines and other vehicles and also for field networking
- **Data Storage**  
Used for data transmission
- **Telecommunications**  
Fiber is laid and used for transmitting and receiving purposes
- **Networking**  
Used to connect users and servers in a variety of network settings and help increase the speed and accuracy of data transmission
- **Industrial/Commercial**  
Used for imaging in hard to reach areas, as wiring where EMI is an issue, as sensory devices to make temperature, pressure and other measurements, and as wiring in automobiles and in industrial settings
- **Broadcast/CATV**  
Broadcast/cable companies are using fiber optic cables for wiring CATV, HDTV, internet, video on-demand and other applications

## EM SPECTRUM

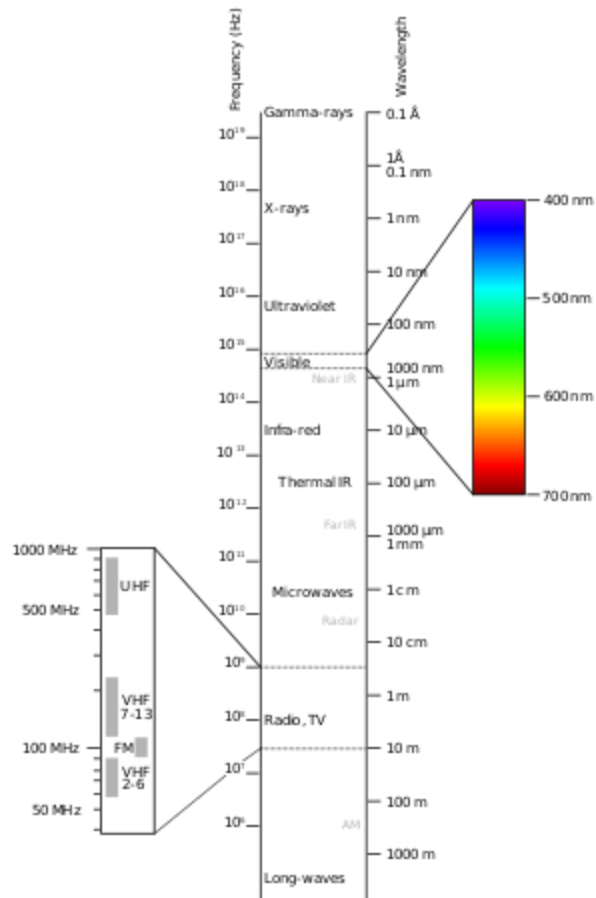

## CRITICAL ANGLE

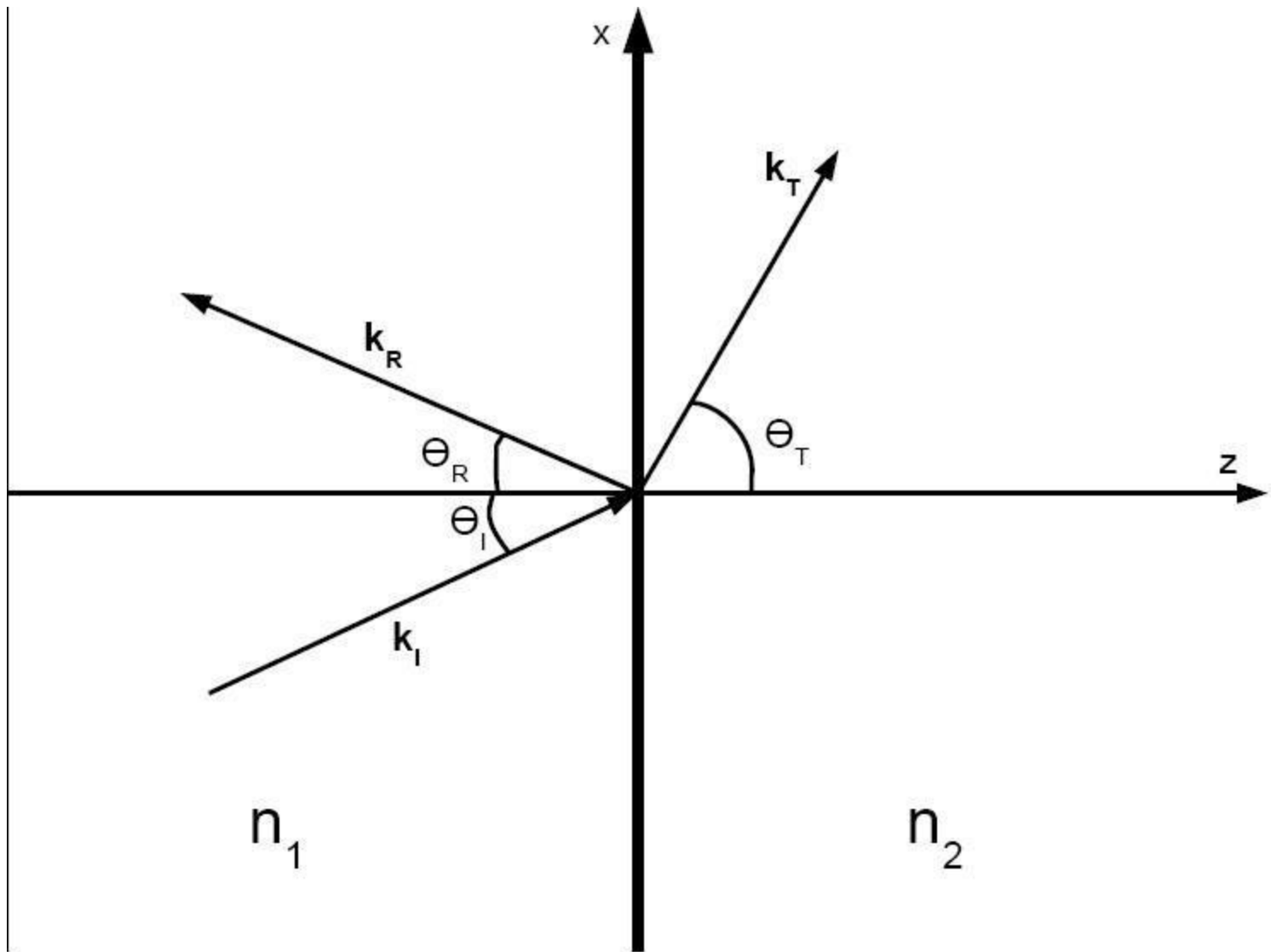

The *critical angle* is the angle of incidence for which the angle of refraction is  $90^\circ$ . The angle of incidence is measured with respect to the normal at the refractive boundary (see diagram illustrating Snell's law). Consider a light ray passing from glass into air. The light emanating from the interface is bent towards the glass. When the incident angle is increased sufficiently, the transmitted angle (in air) reaches  $90$  degrees. It is at this point no light is transmitted into air. The critical angle is given by Snell's law,

Rearranging Snell's Law, we get incidence

To find the critical angle, we find the value for when  $90^\circ$  and thus . The resulting value of is equal to the critical angle . Now, we can solve for , and we get the equation for the critical angle:  
 If the incident ray is precisely at the critical angle, the refracted ray is tangent to the boundary at the point of incidence. If for example, visible light were traveling through acrylic glass (with an index of refraction of approximately 1.50) into air (with an index of refraction of 1.00), the calculation would give the critical angle for light from acrylic into air, which is

Light incident on the border with an angle less than  $41.8^\circ$  would be partially transmitted, while light incident on the border at larger angles with respect to normal would be totally internally reflected.

If the fraction is greater than 1, then arcsine is not defined—meaning that total internal reflection does not occur even at very shallow or grazing incident angles.

So the critical angle is only defined when is less than or equal to 1.

## TOTAL INTERNAL REFLECTION

**Total internal reflection** is the phenomenon which occurs when a propagated wave strikes a medium boundary at an angle larger than a particular critical angle with respect to the normal to the surface. If the refractive index is lower on the other side of the boundary and the incident angle is greater than the critical angle, the wave cannot pass through and is entirely reflected. The **critical angle** is the angle of incidence above which the total internal reflection occurs. This is particularly common as an optical phenomenon, where light waves are involved, but it occurs with many types of waves, such as electromagnetic waves in general or sound waves. When a wave reaches a boundary between different materials with different refractive indices, the wave will in general be partially refracted at the boundary surface, and partially reflected. However, if the angle of incidence is greater (i.e. the direction of propagation is closer to being parallel to the boundary) than the critical angle – the angle of incidence at which light is refracted such that it travels along the boundary – then the wave will not cross the boundary, but will instead be totally reflected back internally. This can only occur when the wave in a medium with a higher refractive index ( $n_1$ ) reaches a boundary with a medium of lower refractive index ( $n_2$ ). For example, it will occur with light reaching air from glass, but not when reaching glass from air.

## NUMERICAL APERTURE

In optics, the **numerical aperture (NA)** of an optical system is a dimensionless number that characterizes the range of angles over which the system can accept or emit light. By incorporating index of refraction in its definition, NA has the property that it is constant for a beam as it goes from one material to another, provided there is no refractive power at the interface. The exact definition of the term varies slightly between different areas of optics. Numerical aperture is commonly used in microscopy to describe the acceptance cone of an objective (and hence its light-gathering ability and resolution), and in fiber optics, in which it describes the range of angles within which light that is incident on the fiber will be transmitted along it.



# OPTICAL FIBERS AND CABLES

## Types Of Optical Fiber

The properties of data transmission via a fiber optic depend on the core. Hence, based on the differences in the structure of the core, there are three main types of optical fibers.

1. Single mode optical fiber
2. Multimode optical fiber with stepped index
3. Multimode optical fiber with graded index
4. [Microstructured optical fibers](#) are a new kind of optical fibers that are different from the above three in a few areas. The core difference is the way in which light is controlled in single/multimode fibers and microstructured optical fibers.

Using optical fibers for communication has a practicality associated with it. Communication engineers or network technicians need be aware of their basics well before designing a network of optical fibers so that they can take quick decisions. The various types of optical fibers listed above come with varying degrees of costs, functionalities, back draws, types of end devices like transceivers, and skills required to work with them. Knowing about them will help you to make a smart trade-off based on your requirements.

### Single mode, multi mode.

Our intention is to transfer data using light. Hence, we are using optical fibers which are special cables that can guide a light beam. That essentially makes them waveguides because light is a wave.

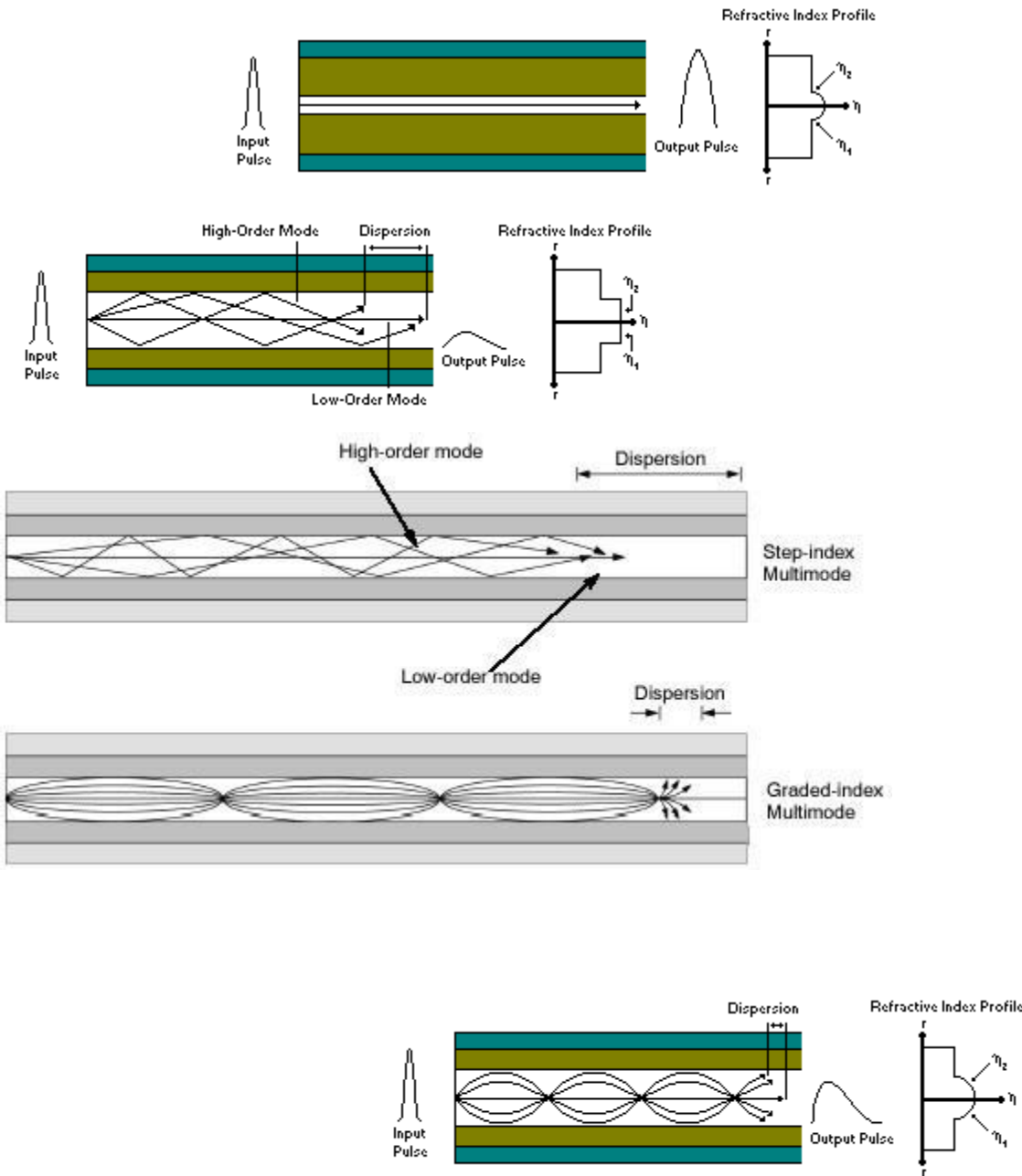

## BASIC STRUCTURE OF AN OPTICAL FIBER

The basic structure of an optical fiber consists of three parts; the **core**, the **cladding**, and the **coating** or **buffer**. The basic structure of an optical fiber is shown in figure 2-9. The **core** is a cylindrical rod of dielectric material. Dielectric material conducts no [electricity](#). Light propagates mainly along the core of the fiber. The core is generally made of glass. The **core** is described as having a radius of (a) and an index of refraction  $n_1$ . The core is surrounded by a layer of material called the **cladding**. Even though light will propagate along the fiber core without the layer of cladding material, the cladding does perform some necessary functions.

Figure 2-9. - Basic structure of an optical fiber.

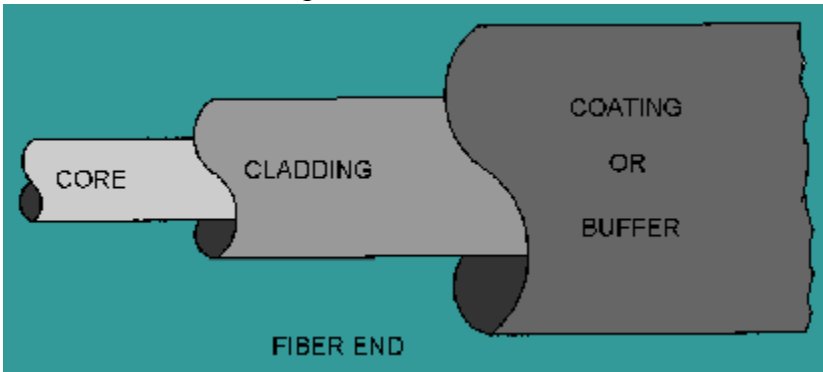

The **cladding** layer is made of a dielectric material with an index of [refraction](#)  $n_2$ . The index of [refraction](#) of the cladding material is less than that of the core material. The cladding is generally made of glass or plastic. The cladding performs the following functions:

- Reduces loss of light from the core into the surrounding air
- Reduces scattering loss at the surface of the core
- Protects the fiber from absorbing surface [contaminants](#)
- Adds mechanical strength

For extra protection, the cladding is enclosed in an additional layer called the **coating** or **buffer**. The **coating** or **buffer** is a layer of material used to protect an optical fiber from physical damage. The material used for a buffer is a type of plastic

[Home](#) » [Assemblies Options](#) » Plastic Clad Silica Fibers

## Plastic Clad Silica Fibers

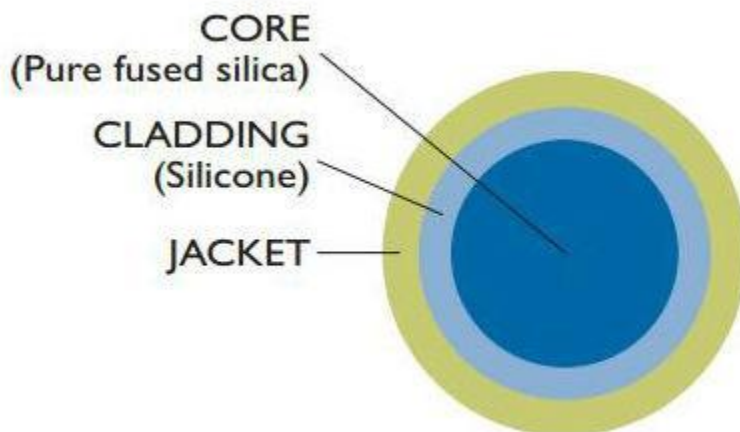

Features

- Cost effective alternative to all silica fibers
- Better UV and NIR transmission than hard clad silica (HPCS) fibers
- UV/VIS and VIS/NIR types available
- High numerical aperture
- Biocompatible materials

- Sterilizable by ETO, gamma radiation
- Radiation resistant
- Core diameter up to 2 mm
- High concentricity

### **Fiber Properties**

- Step index profile
- Numerical aperture: 0.37  
(2 meters, falls to 0.30 for large lengths)
- Proof test: 70 kpsi
- Minimum bend radius:  
100 times the clad radius (momentary)  
600 times the clad radius (long term)
- Laser damage threshold:  
> 100 kW/mm<sup>2</sup> (Nd:YAG, cw at 1064 nm)

### **Applications**

- Medical
- Laser surgery
- Angioplasty
- Dermatology
- Urology
- Photodynamic therapy
- Diagnostics

#### Industrial/Scientific

- Spectroscopy
- Remote illumination
- Remote sensing
- Laser diode coupling
- Laser beam delivery
- Laser welding, marking, cutting and soldering

### **Optical Fiber Cables**

An **optical fiber cable**, also known as a **fiber optic cable**, is an assembly similar to an electrical cable, but containing one or more optical fibers that are used to carry light. The optical fiber elements are typically individually coated with plastic layers and contained in a protective tube suitable for the environment where the cable will be deployed. Different types of cable are used for different applications, for example long distance telecommunication, or providing a high-speed data connection between different parts of a building.

### **Acceptance Angle**

The "acceptance angle" figure illustrates this concept.

The concentrator is a [lens](#) with a receiver *R*. The left section of the figure shows a set of parallel [rays](#) incident on the concentrator at an angle  $\alpha < \theta$  to the [optical axis](#). All rays end up on the receiver and, therefore, all light is captured. In the center, this figure shows another set of parallel rays, now incident on the concentrator at an angle  $\alpha = \theta$  to the optical axis. For an ideal concentrator, all rays are still captured. However, on the right, this figure shows yet another set of parallel rays, now incident on the concentrator at an angle  $\alpha > \theta$  to the optical axis. All rays now miss the receiver and all light is lost. Therefore, for incidence angles  $\alpha < \theta$  all light is captured while for incidence angles  $\alpha > \theta$  all light is lost. The concentrator is then said to have an (half) acceptance angle  $\theta$ , or a total acceptance angle  $2\theta$  (since it accepts light within an angle  $\pm\theta$  to the optical axis).

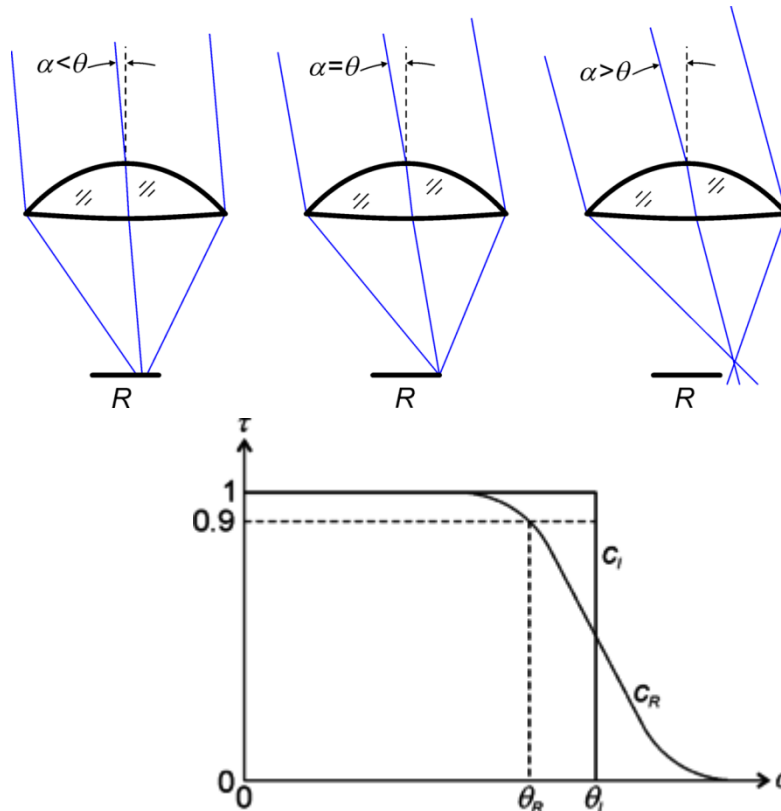

### Transmission curves

Ideally, a solar concentrator has a [transmission curve](#)  $c_1$  as shown in the "transmission curves" figure. Transmission (efficiency) is  $\tau = 1$  for all incidence angles  $\alpha < \theta_1$  and  $\tau = 0$  for all incidence angles  $\alpha > \theta_1$ .

In practice, real transmission curves are not perfect and they typically have a shape similar to that of curve  $c_R$ , which is normalized so that  $\tau = 1$  for  $\alpha = 0$ . In that case, the real acceptance angle  $\theta_R$  is typically defined as the angle for which transmission  $\tau$  drops to 90% of its maximum. <sup>[1]</sup>

For line-focus systems, such as a [trough concentrator](#) or a linear [Fresnel lens](#), the acceptance angle is one dimensional, and the concentration has only weak dependence on off-pointing perpendicular to the focus direction. Point focus systems, on the other hand, are sensitive to off-pointing in both directions. In the general case, the acceptance angle in one direction may be different from the other.

## Fiber Optic Cable Types

### Simplex Cable

Single strand of fiber surrounded by a 900 um buffer then a layer of Kevlar and finally the outer jacket.

Available in 2mm or 3mm

Plenum or Riser Jacket.

Plenum is stronger and made to chare in fire versus riser is made to melt in fire.Riser cable is more flexible.

## **Duplex Cable**

In data communications, the simultaneous operation of a circuit in both directions is known as full duplex; if only one transmitter can send at a time, the system is called half duplex.

Two single strands of fiber optic cable attached at the center. Surrounded by a 900 um buffer then a layer of Kevlar and finally the outer jacket.

Available in 2mm or 3mm

Plenum or Riser Jacket. Plenum is stronger and made to char in fire versus riser is made to melt in fire. Riser cable is more flexible.

## **Fiber Optic Ribbon**

A coherent optical fiber bundle in which the configuration is flat rather than round, giving an output in a line. Fiber optic ribbon cable is available bare (without a jacket or Kevlar and also available with a plenum jacket or riser jacket. A typical ribbon has 12 color coded fibers and cables can be made with multiple ribbons. The jackets on ribbon cable are oval and can be broken out into fanout assemblies providing individual single connectors or using a MTP connector for multiple fibers being terminated with one connector.

## **Loose Tube**

Loose Tube are 250 um fibers inside of a smooth tube normally submerged in a water resistant gel but can be dry. The tubes (normally multiple) are then surrounded by a water resistant tape and all tubes are incased inside a protective outer jacket. There are many different types and fiber counts. Depending on how ordered, some tubes may be empty.

## **Distribution**

This compact building cable consists of individual 900µm buffered fiber, is smaller in size and costs less than breakout cable. Connectors may be installed directly on 900µm buffered fiber at breakout box locations.

## **Breakout**

This cable consists of several simplex tight buffer fibers contained within an outer jacket. Breakout cable enables the quick installation of connectors onto 2+mm robust jacketed fiber.

# **Losses in optical fiber**

Loss characteristics of Optical fiber:

1. Attenuation
2. Absorption
3. Scattering
4. Banding loss
5. Dispersion Loss
6. Coupling losses

## 1. Attenuation:

• Attenuation is the loss of optical energy as it travels through the fiber; this loss is measured in dB/km.

• Attenuation is a transmission loss that can be measured as a difference between the output signal power and the input signal power.

Attenuation is a measure of the loss of signal strength or light power that occurs as light pulses propagate through a run of multimode or single-mode fiber. Attenuation in fiber optics, also known as transmission loss, is the reduction in intensity of the light beam (or signal) with respect to distance traveled through a transmission medium. Causes of Attenuation: Empirical research has shown that attenuation in optical fiber is caused primarily by both

## Absorption

Absorption is uniform. The same amount of the same material always absorbs the same fraction of light at the same wavelength. If you have three blocks of the same type of glass, each 1-centimeter thick, all three will absorb the same fraction of the light passing through them.

Absorption also is cumulative, so it depends on the total amount of material the light passes through. If the absorption is 1% per centimeter, it absorbs 1% of the light in the first centimeter, and 1% of the *remaining* light the next centimeter, and so on.

## Intrinsic Material Absorption

Intrinsic absorption is caused by interaction of the propagating light wave with one or more major components of glass that constitute the fiber's material composition. These losses represent a fundamental minimum to the attainable loss and can be overcome only by changing the fiber material.

An example of such an interaction is the *infrared absorption band* of SiO<sub>2</sub> shown in the above figure. However, in the wavelength regions of interest to optical communication (0.8-0.9 μm and 1.2-1.5 μm), infrared absorption tails make negligible contributions.

## Extrinsic Impurity Ions Absorption

Extrinsic impurity ions absorption is caused by the presence of minute quantities of metallic ions (such as Fe<sup>2+</sup>, Cu<sup>2+</sup>, Cr<sup>3+</sup>) and the OH<sup>-</sup> ion from water dissolved in glass. The attenuation from these impurity ions is shown in the following table. From the table above, we can see that 1 part per million (ppm) of Fe<sup>2+</sup> would lead to a loss of 0.68 dB/km at 1.1 μm. This shows the necessity of ultrapure fibers. Luckily, losses due to the metallic ions can be reduced to very low by refining the glass mixture to an impurity level below 1 part per billion (ppb).

The OH<sup>-</sup> ion from water vapor in the glass leads to absorption peaks at 0.72 μm, 0.88 μm, 0.95 μm, 1.13 μm, 1.24 μm and 1.38 μm. The broad peaks at 1.24 μm and 1.38 μm in the first figure are due to OH<sup>-</sup> ion. The good news is OH<sup>-</sup> ion absorption band is narrow enough that ultrapure fibers can achieve losses less than 0.2 dB/km at 1.55 μm.

With new manufacturing techniques, we can reduce the OH<sup>-</sup> ion content to below 1 part per billion (ppb). The results are ultra-low-loss fibers which have a wider low-loss window in silica glass fibers shown in the following figure. This

improvement enables the use of WDM technology in fiber optic networks, which dramatically increased the capacity of fiber optic systems.

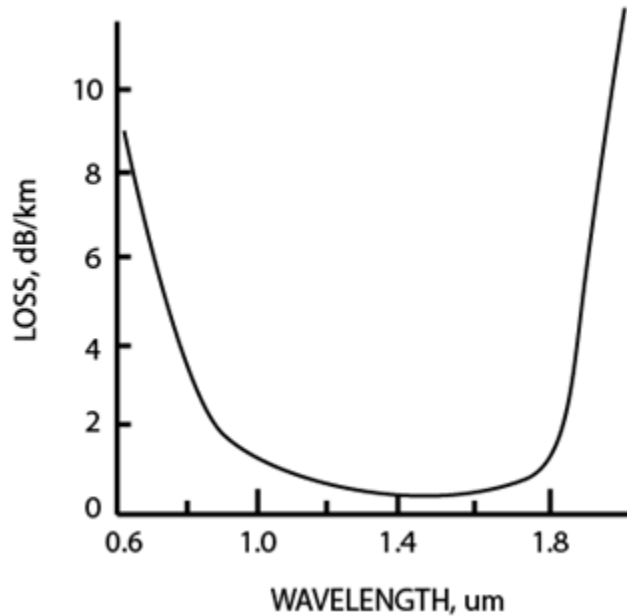

## Scattering

Scattering losses occur when a wave interacts with a particle in a way that removes energy in the directional propagating wave and transfers it to other directions. The light isn't absorbed, just sent in another direction. However, the distinction between scattering and absorption doesn't matter much because the light is lost from the fiber in either case.

There are two main types of scattering: **linear scattering** and **nonlinear scattering**.

For **linear scattering**, the amount of light power that is transferred from a wave is proportional to the power in the wave. It is characterized by having no change in frequency in the scattered wave.

On the other hand, **nonlinear scattering** is accompanied by a frequency shift of the scattered light. Nonlinear scattering is caused by high values of electric field within the fiber (modest to high amount of optical power). Nonlinear scattering causes significant power to be scattered in the forward, backward, or sideways directions.

### Rayleigh Scattering (Linear Scattering)

Rayleigh scattering (named after the British physicist Lord Rayleigh) is the main type of linear scattering. It is caused by small-scale (small compared with the wavelength of the lightwave) inhomogeneities that are produced in the fiber fabrication process. Examples of inhomogeneities are glass composition fluctuations (which results in minute refractive index change) and density fluctuations (fundamental and not improvable). Rayleigh scattering accounts for about 96% of attenuation in optical fiber.

As light travels in the core, it interacts with the silica molecules in the core. These elastic collisions between the light wave and the silica molecules result in Rayleigh scattering. If the scattered light maintains an angle that supports forward travel within the core, no attenuation occurs. If the light is scattered at an angle that does not support continued forward travel, the light is diverted out of the core and attenuation occurs. Depending on the incident angle, some portion of the light propagates forward and the other part deviates out of the propagation path and escapes from the fiber core. Some scattered light is reflected back toward the light source. This is a property that is used in an OTDR (Optical Time Domain Reflectometer) to test fibers.



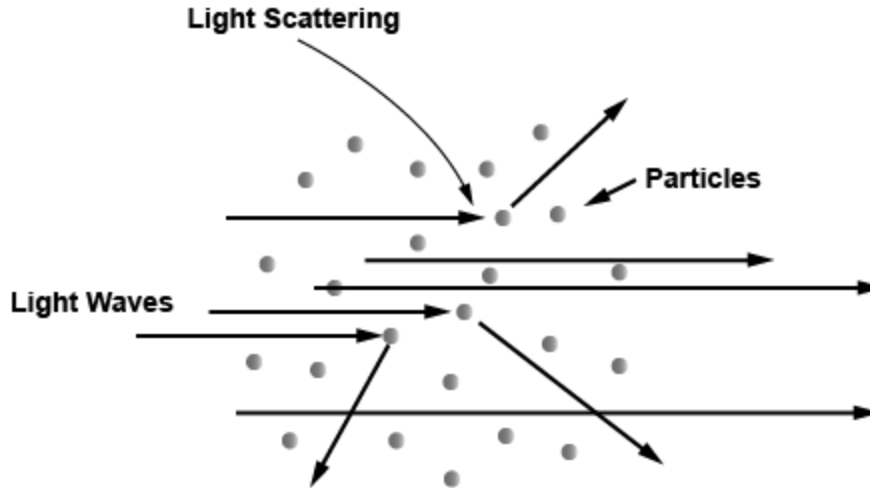

Rayleigh scattering describes the elastic scattering of light by particles which are much smaller than the wavelength of light. The intensity of the scattered radiation is given by

$$I = I_0 \left( \frac{1 + \cos^2 \theta}{2R^2} \right) \left( \frac{2\pi}{\lambda} \right)^4 \left( \frac{n^2 - 1}{n^2 + 2} \right)^2 \left( \frac{d}{2} \right)^6 ,$$

where  $R$  is the distance between the particle and the observer,  $\theta$  is the scattering angle,  $n$  is the refractive index of the particle, and  $d$  is the diameter of the particle.

The size of a scattering particle is parameterized by the ratio  $x$  of its characteristic dimension  $r$  and wavelength  $\lambda$ :

$$x = \frac{2\pi r}{\lambda} .$$

Rayleigh scattering can be defined as scattering in the small size parameter regime  $x \ll 1$ . Scattering from larger particles is explained by the Mie scattering for an arbitrary size parameter  $x$ . For small  $x$  the Mie theory reduces to the Rayleigh approximation.

It can be seen from the above equation that Rayleigh scattering is strongly dependent upon the size of the particle and the wavelengths. The intensity of the Rayleigh scattered radiation increases rapidly as the ratio of particle size to wavelength increases. Furthermore, the intensity of Rayleigh scattered radiation is identical in the forward and reverse directions. The Rayleigh scattering model breaks down when the particle size becomes larger than around 10% of the wavelength of the incident radiation. In the case of particles with dimensions greater than this, Mie's scattering model can be used to find the intensity of the scattered radiation.

Rayleigh scattering depends not on the specific type of material but on the size of the particles relative to the wavelength of light. The loss due to Rayleigh scattering is proportional to  $\lambda^{-4}$  and obviously decreases rapidly with increase in wavelength (see the first figure above – Loss vs.. Wavelength). Short wavelengths are scattered more than longer wavelengths. Any wavelength that is below 800nm is unusable for optical communication because attenuation due to Rayleigh scattering is too high.

The attenuation coefficient due to Rayleigh scattering in (pure) fused silica is given by the following approximate

$$\alpha(\lambda) = \alpha_0 \left( \frac{\lambda_0}{\lambda} \right)^4$$

formula

where

$$\alpha_0 = 1.7 \text{ dB/km} \quad \text{at } \lambda_0 = 0.85 \mu\text{m}$$

The above formula predicts the Rayleigh scattering loss to be 0.31 dB/km at 1.3 $\mu\text{m}$  and 0.15 dB/km at 1.55 $\mu\text{m}$  wavelengths.

### Intrinsic Losses of Silica Fiber

From the figure above (you can also refer to the first figure in this tutorial), we can see that the fundamental loss limits for a silica-based glass fibers are the Rayleigh scattering at short wavelengths and the material absorption (the infrared absorption) properties of silica (SiO<sub>2</sub>) at long wavelengths. A theoretical attenuation minimum for silica fibers can be predicted at a wavelength of 1550nm where the two curves cross. This has been one reason for laser sources and receivers that work in this portion of the spectrum.

## Mie Scattering (Linear Scattering)

Mie scattering is named after German physicist Gustav Mie. This theory describes scattering of electromagnetic radiation by particles that are comparable in size to a wavelength (larger than 10% of wavelength).

For particles much larger, and much smaller than the wavelength of scattered light there are simple and excellent approximations that suffice.

For glass fibers, Mie scattering occurs in inhomogeneities such as core-cladding refractive index variations over the length of the fiber, impurities at the core-cladding interface, strains or bubbles in the fiber, or diameter fluctuations. Mie scattering can be reduced by carefully removing imperfections from the glass material, carefully controlling the quality and cleanliness of the manufacturing process.

In commercial fibers, the effects of Mie scattering are insignificant. Optical fibers are manufactured with very few large defects. (larger than 10% of wavelength)

Here is an [interactive Mie Scattering calculator](#) on the web developed by Scott Prahl.

## Brillouin Scattering (Nonlinear Scattering)

Brillouin scattering is caused by the nonlinearity of a medium. In glass fibers, Brillouin scattering shows as a modulation of the light by the thermal energy in the material.

An incident photon can be converted into a scattered photon of slightly lower energy, usually propagating in the backward direction, and a phonon (vibrational energy). This coupling of optical fields and acoustic waves occurs via electrostriction.

The frequency of the reflected beam is slightly lower than that of the incident beam; the frequency difference  $\nu_B$  corresponds to the frequency of emitted phonons. This is called Brillouin Frequency Shift. This phenomenon has been used for fiber optic sensor applications.

Brillouin scattering can occur spontaneously even at low optical powers. This is different than Stimulated Brillouin Scattering which requires optical power to meet a threshold high enough to happen.

Above a certain threshold power, stimulated Brillouin scattering can reflect most of the power of an incident beam. The optical power level at which stimulated Brillouin scattering becomes significant in a single mode fiber is given by the empirical formula below.

$$P_B = (17.6 \times 10^{-3}) a'^2 \lambda'^2 \alpha \Delta\nu'$$

where

$P_B$  = Stimulated Brillouin Scattering Optical Power Level Threshold (watts)

$a'$  = Fiber radius (um)

$\lambda'$  = Light source wavelength (um)

$\alpha$  = Fiber loss (dB/km)

$\Delta\nu'$  = Light source linewidth (GHz)

## Stimulated Raman Scattering (Nonlinear Scattering)

Stimulated Raman scattering is a nonlinear response of glass fibers to the optical intensity of light. This is caused by vibrations of the crystal (or glass) lattice. Stimulated Raman scattering produces a high-frequency optical phonon, as compared to Brillouin scattering, which produces a low-frequency acoustical phonon, and a scattered photon.

When two laser beams with different wavelengths (and normally with the same polarization direction) propagate together through a Raman-active medium, the longer wavelength beam can experience optical amplification at the expense of the shorter wavelength beam. This phenomenon has been used for Raman amplifiers and Raman lasers.

In Stimulated Raman scattering, the scattering is predominately in the forward direction, hence the power is not lost to the receiver.

Stimulated Raman Scattering also requires optical power to be higher than a threshold to happen. The formula below

gives the threshold  $P_R = (23.6 \times 10^{-2})a'^2\lambda'\alpha$

where

$P_R$  = Stimulated Raman Scattering Optical Power Level Threshold (watts)

$a'$  = Fiber radius (um)

$\lambda'$  = Light source wavelength (um)

$\alpha$  = Fiber loss (dB/km)

**Bending losses** The loss which exists when an optical fiber undergoes bending is called bending losses. There are two types of bending

- i) **Macroscopic bending** Bending in which complete fiber undergoes bends which causes certain modes not to be reflected and therefore causes loss to the cladding.
- ii) **Microscopic Bending** Either the core or cladding undergoes slight bends at its surface. It causes light to be reflected at angles when there is no further reflection.

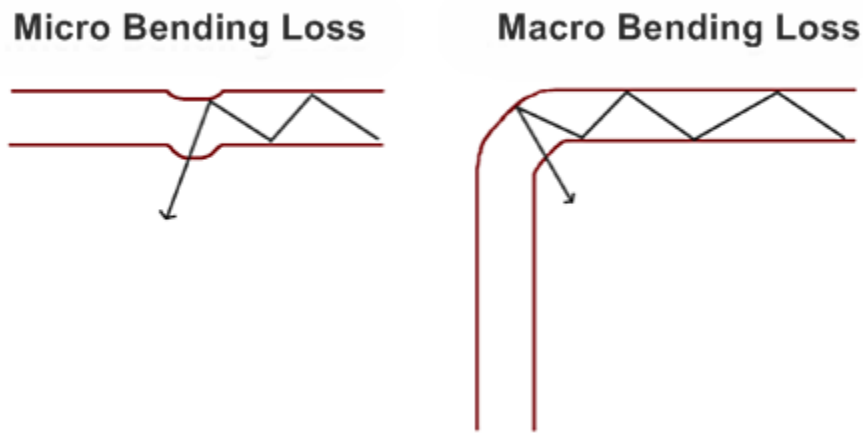

## Disprasion

As waves propagate they may become wider; this is known as dispersion. The amplitude of waves may decrease; this is known as attenuation. Low attenuation is critical for long distance communication fibers since reamplification of the signal is expensive and complicated. Dispersion causes an overlap of information carrying pulses which decreases the information carrying capacity of an amplitude modulated fiber. We want to design fibers that can carry a very sharp pulse with little dispersion.

## Modal Dispersion

The speed that a ray travels down a fiber depends on its internal angle  $q$ . When there are several modes at different angles then the path that each mode takes is different and the arrival time of a bit is different. The time it takes for a mode to move down a fiber:

Minimum for  $q \sim 90^\circ$

Maximum for  $q = q_c$

$$\Delta\tau_{min} = \frac{Ln_1}{c \sin 90^\circ} = \frac{Ln_1}{c}$$

$$\Delta\tau_{max} = \frac{Ln_1}{c \sin \theta_c} = \frac{Ln_1^2}{cn_2}$$

This makes sense because if the angle is  $90^\circ$  the mode can propagate down the center without interacting with the cladding.

The maximum difference in time of travel of two modes (one mode at  $90^\circ$  and one at cut-off) can be written:

$$\Delta\tau^{SI} = \Delta\tau_{max} - \Delta\tau_{min}$$

$$\Delta\tau^{SI} = \frac{L}{c} \frac{n_1}{n_2} (n_1 - n_2)$$

Thus the Dt (and therefore intermodal dispersion) is proportional to the difference between the indices of refraction. For small fiber lengths up to 1 km the intermodal dispersion is proportional to L.

Example:

For  $n_1 = 1.48$ ,  $n_2 = 1.46$  and  $L = 1\text{km}$

$$\Delta\tau^{SI} = \frac{1 \times 10^3}{1 \times 10^8} \frac{1.48}{1.46} (1.48 - 1.46) \text{ s}$$

So

$$\Delta\tau^{SI} = 6.76 \times 10^{-8} \text{ or } 68 \text{ ns}$$

This means that for a gigabyte transfer rate after only one km there would be 70 bits that have overlapped and would be lost due to intermodal dispersion.

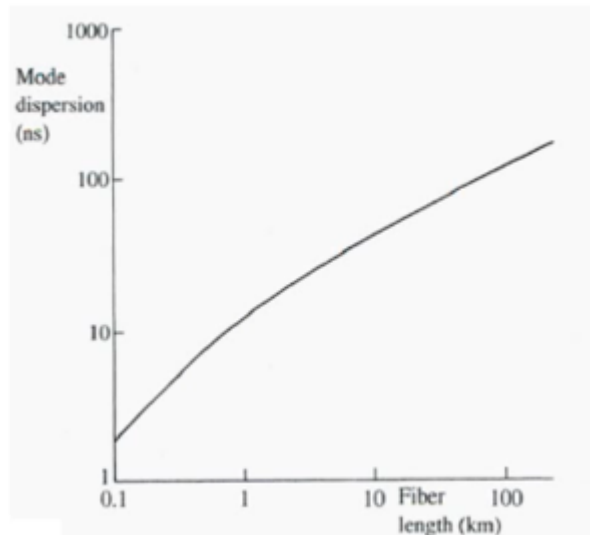

At distances larger than 1km the intermodal dispersion becomes approximately proportional to the square root of the length and is a significant limiting factor.

The lower rate of increase of dispersion at longer distances is due to mode coupling. Long fibers are not perfectly straight but have small kinks or microbends. A bend acts to realign a mode by slightly changing the angle of incidence over the bended portion. This additive effect tends to recouple or reduce the dispersion of modes that had become dispersed.

Intermodal dispersion may be alleviated by either using a single mode fiber ( a fiber with a V parameter  $< \pi/2$ ), or by designing a fiber where the mode velocities are more nearly equal as in a graded index fiber.

**Material Dispersion:** Also known as spectral dispersion or chromatic dispersion. Results because of variation due to Refractive Index  $n$  of core as a function of wavelength, because of which pulse spreading occurs even when different wavelengths follow the same path. 2) Waveguide Dispersion: Whenever any optical signal is passed through the optical fiber, practically 80% of optical power is confined to core & rest 20% optical power into cladding.

## Waveguide dispersion

Waveguide dispersion is minimal at 1.3 $\mu\text{m}$  and 1.4 $\mu\text{m}$  wavelength for  $\text{SiO}_2$

Waveguide dispersion arises because the mode propagation velocity itself depends on wavelength regardless of any refractive index variation of the medium. Waveguide dispersion can not be neglected.

The graph shows both material and waveguide dispersion as a function of wavelength. Temporal dispersion is measured in units of picosecond  $\mu\text{m}^{-1} \text{ km}^{-1}$ . Dispersion remains small in the 1.3 to 1.5  $\mu\text{m}$  wavelength range.

Attenuation: intrinsic fiber losses.

$$\text{attenuation} = : \frac{10 \log_{10}(P_i/P_f)}{L} \text{ dB km}^{-1}$$

where

$P_i$  is the input power

$P_f$  is the final power

$L$  is length

Attenuation is expressed in decibels. This would have the unit Bells per meter, and multiplied by 10 it becomes decibels.

Intrinsic losses in silica fibers have two main sources; scattering losses and absorption losses.

**SECTION 5: OPTICAL AMPLIFIERS**

## OPTICAL AMPLIFIER

- In order to transmit signals over long distances (>100 km) it is necessary to compensate for *attenuation losses* within the fiber.
- Initially this was accomplished with an optoelectronic module consisting of an optical receiver, a regeneration and equalization system, and an optical transmitter to send the data.
- Although functional this arrangement is limited by the optical to electrical and electrical to optical conversions.

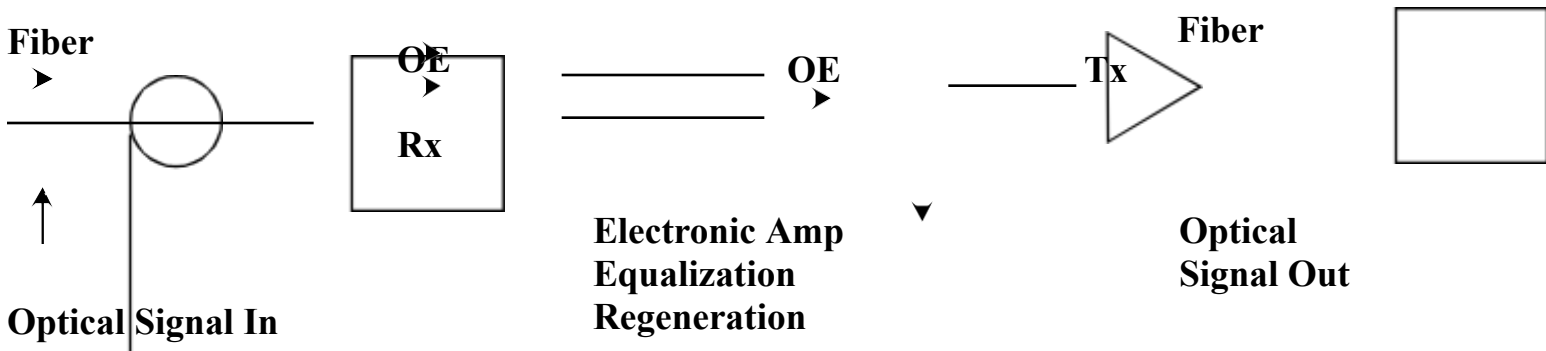

- Several types of *optical amplifiers* have since been demonstrated to replace the OE – electronic regeneration systems.
- These systems eliminate the need for E-O and O-E conversions.
- This is one of the main reasons for the success of today's optical communications systems.

## OPTICAL AMPLIFIERS

The general form of an optical amplifier:

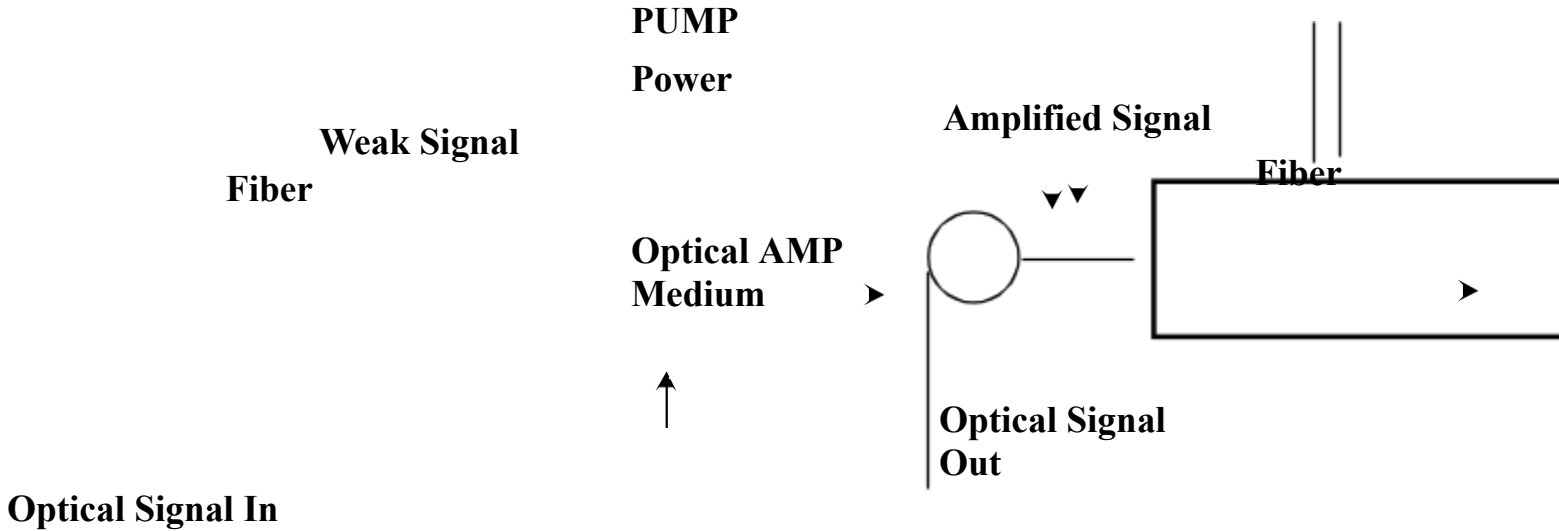

Some types of OAs that have been demonstrated include:

- *Semiconductor optical amplifiers (SOAs)*
- *Fiber Raman and Brillouin amplifiers*
- *Rare earth doped fiber amplifiers (erbium – EDFA 1500 nm, praseodymium – PDFFA 1300 nm)*

The most practical optical amplifiers to date include the SOA and EDFA types. New pumping methods and materials are also improving the performance of Raman amplifiers.



### Characteristics of SOA types:

- Polarization dependent – require polarization maintaining fiber
- Relatively high gain ~20 dB
- Output saturation power 5-10 dBm
- Large BW
- Can operate at 800, 1300, and 1500 nm wavelength regions.
- Compact and easily integrated with other devices
- Can be integrated into arrays
- High *noise figure* and cross-talk levels due to *nonlinear phenomenon* such as 4-wave mixing.

This last feature restricts the use of SOAs.

- *Semiconductor Optical Amplifier (SOA)* – similar to a laser cavity. Used as a discrete amplifiers. They can be integrated into arrays of amplifying switching and gating devices. Finding application in all optical 3R-regeneration systems.

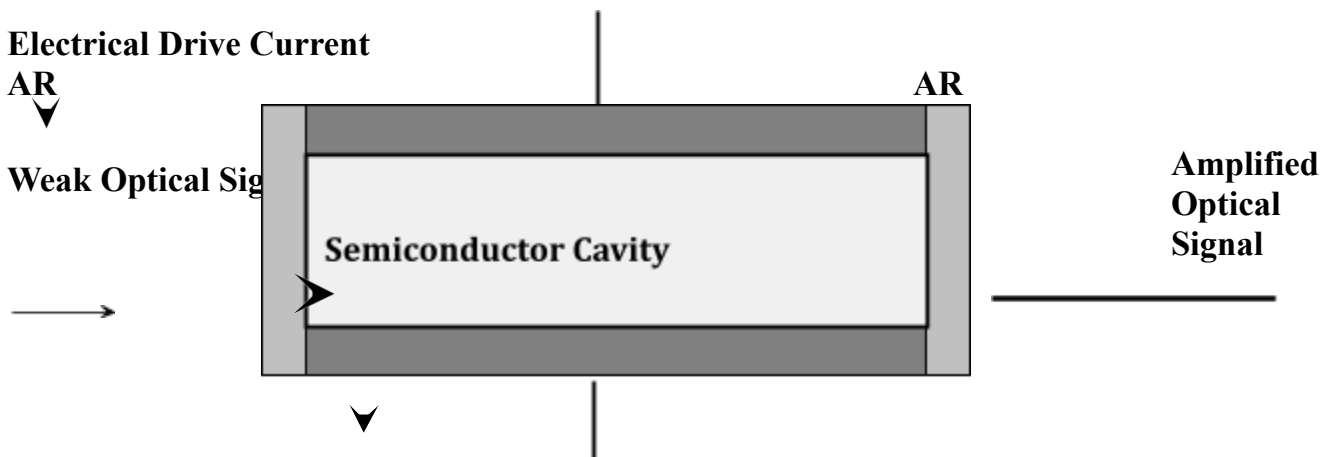

- Limited in operation below 10 Gb/s. (Higher rates are possible with lower gain.)

### **Rare Earth Doped Fiber Amplifier Characteristics:**

Rare earth doped fiber amplifiers are finding increasing importance in optical communications systems. Perhaps the most important version is erbium doped fiber amplifiers (EDFAs) due to their ability to amplify signals at the low loss 1.55  $\mu\text{m}$  wavelength range.

### **Characteristics of EDFAs (advantages):**

- High power transfer efficiency from pump to signal power ( $> 50\%$ ).
- Wide spectral band amplification with relative flat gain ( $>20$  dB) – useful for WDM applications.
- Saturation output  $> 1$  mW (10 to 25 dBm).
- Gain-time constant long ( $>100$  msec) to overcome patterning effects and inter-modulation distortions ( low noise).
- Large dynamic range.
- Low noise figure.
- *Polarization independent.*
- Suitable for long-haul applications.

### **Disadvantages of EDFAs:**

- Relatively large devices (km lengths of fiber) – not easily integrated with other devices.
- ASE – *amplified spontaneous emission*. There is always some output even with no signal input due to some excitation of ions in the fiber – *spontaneous noise*.
- Cross-talk effects.
- Gain saturation effects.

- An energy level diagram for Er doped silica is shown below.

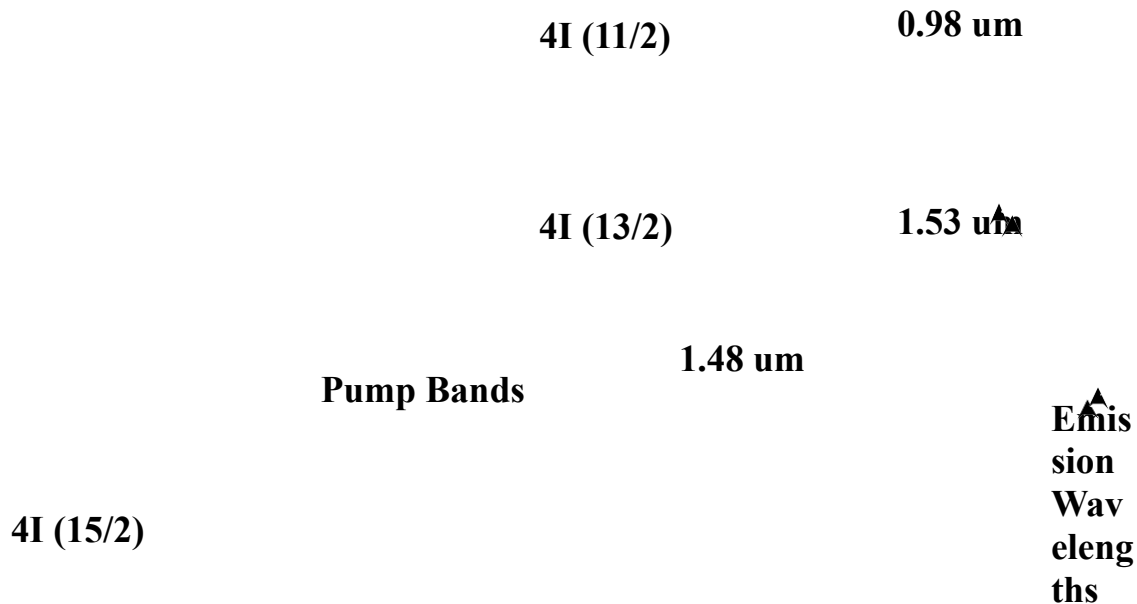

- Pumping* is primarily done *optically* with the primary *pump wavelengths* at 1.48  $\mu\text{m}$  and 0.98  $\mu\text{m}$ . As indicated atoms pumped to the 4I (11/2) 0.98  $\mu\text{m}$  band decays to the primary emission transition band. Pumping with 1.48  $\mu\text{m}$  light is directly to the upper transition levels of the emission band.
- Semiconductor lasers have been developed for both pump wavelengths.
- 10-20 mW of absorbed pump power at these wavelengths can produce 30-40 dB of amplifier gain.
- Pump Efficiencies* of 11 dB/mW achieved at 980 nm.
- Pumping can also be performed at 820 and 670 nm with GaAlAs laser diodes. Pump efficiencies are lower but these lasers can be made with high output power.

## Typical Absorption/Gain Spectrum for Erbium Doped Fiber:

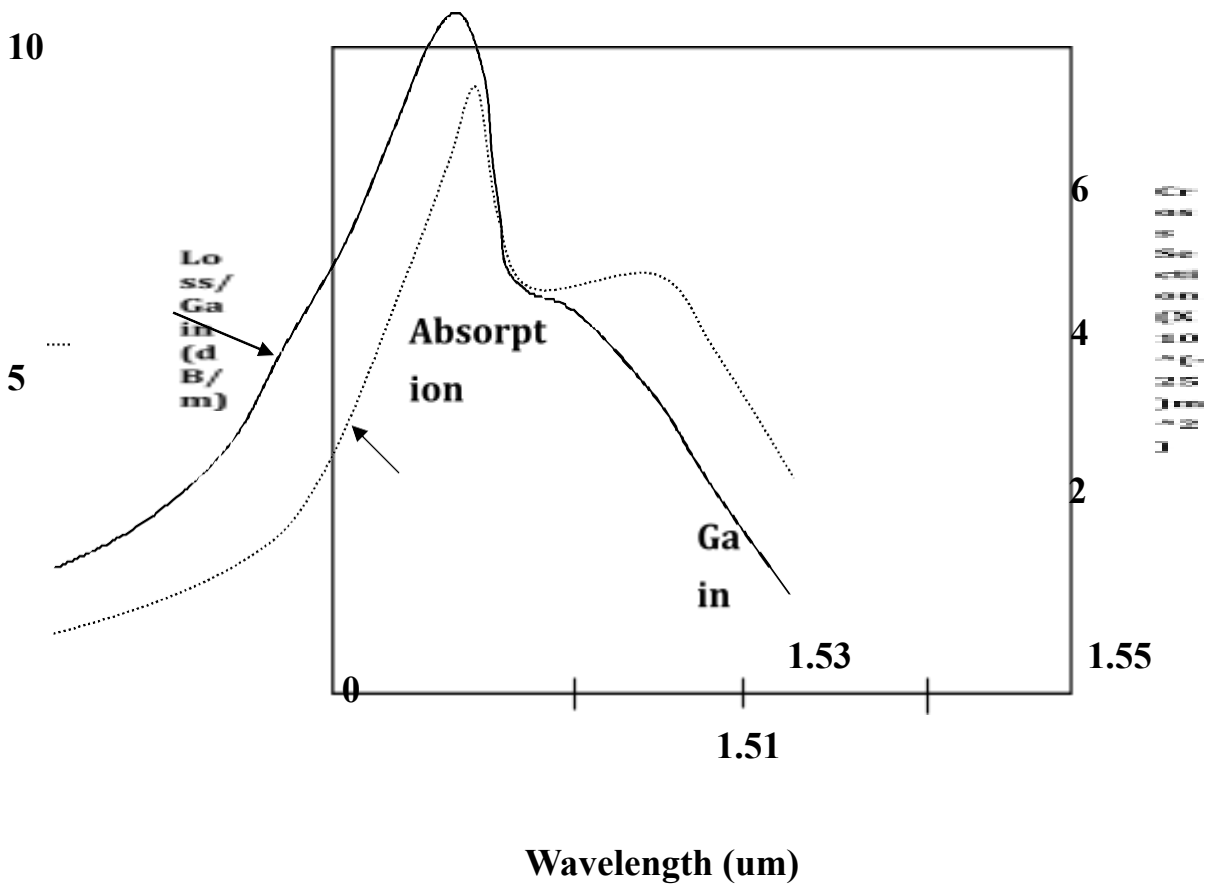

- Since the gain spectrum of erbium resembles a 3-level atom it is possible to model the gain properties using this approach.
- Several different *wavelength bands* have been designated for wavelength division multiplexing and EDFAs have been designed to operate in these bands.
- The divisions have been designated as\*:

***S-Band 1480-1520 nm***

***C-Band 1521-1560 nm***

***L-Band 1561-1620 nm***

(\* Note some variability in these values is common.)

## General EDFA Amplifier Configuration:

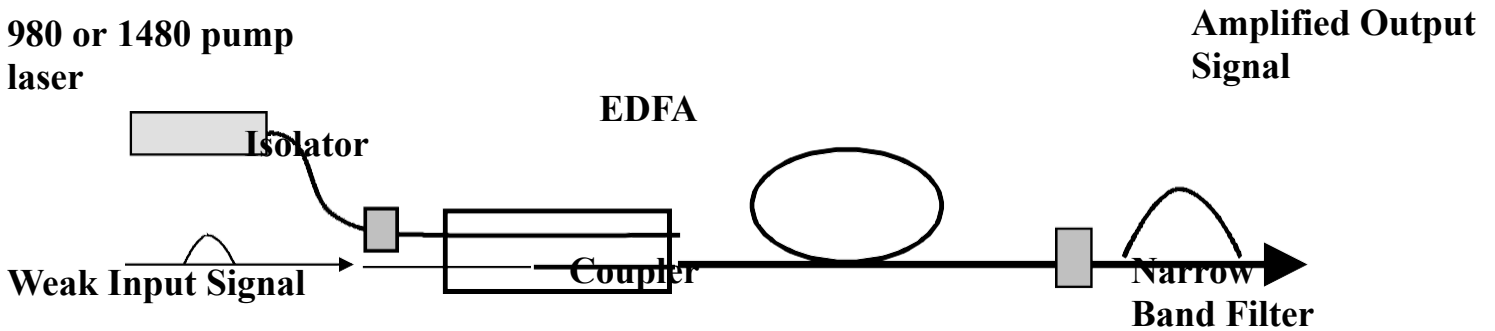

## Basic Amplifier Characteristics

### *Optical Gain*

- Rare earth doped optical amplifiers work much like a laser.
- The primary difference is that they do not have a resonator.
- Amplification occurs primarily through the *stimulated emission* process.
- The medium is pumped until a *population inversion* state is achieved. Pump powers are typically several 20-250 mW. An isolator is used to reduce reflections at the input to the amplifier. A narrow band optical filter is used to reduce transmission of amplified spontaneous emission frequency components.
- The resultant *optical gain* depends both on the optical frequency and the local beam intensity within the amplifier section.
- For basic discussion consider a *two-level homogeneously broadened* medium.

- The gain coefficient  $g_0$  can be expressed as:

$$g(\mathbf{c}) = \frac{g_0}{1 + (\mathbf{c} - \mathbf{c}_0)^2 T^2 + P / P_s}, \quad 2$$

$g_0$  is the peak gain,  $m$  is the optical frequency of the incident signal,

$m_0$  is the transition frequency,  $P$  is the optical power of the incident signal,  $T_2$  is the *dipole relaxation time*, and  $P_s$  is the *saturation power*.

- Typically  $T_2$  is small  $< 1$  ps, and the saturation power  $P_s$  depends on *gain medium* parameters such as the *fluorescence time* and the *transition cross section*.

---

**Gain Spectrum and BW:**

- When not saturated (i.e.  $P/P_s \ll 1$ ) the *gain coefficient*  $g(\omega)$  becomes:

$$g(\omega) = \frac{g_0}{1 + (\omega - \omega_0)^2 T_2^2}$$

- *Gain is maximum* when  $\omega = \omega_0$  (i.e. the gain coefficient is at resonance).
- At non-resonant frequencies the gain follows the *homogeneously broadened* characteristics of a *two level atom* (i.e. Lorentzian profile).
- The *gain BW* for this spectrum is typically expressed as the (Full Width at Half Maximum) FWHM

$$\Delta\omega_g = 2 T_2^{-1}$$

with  $T_2 = 0.1ps$

$\Delta\omega_g$

=

$\frac{g}{g}$

$\frac{2}{m}$

$$\Delta\nu_g = 3THz$$

- *Large Spectral BW amplifiers* are preferred for fiber optic systems to make them less sensitive to dispersed transmitted signals and useful for WDM systems.

**EDFA Gain Spectrum:**

- The gain spectrum of erbium ions alone is *homogeneously broadened* and the BW is determined by the *dipole relaxation time*  $T_2$ .

- However when placed in a *glass host* the spectrum is influenced both by the *silica* and any other *dopants*. This can result in *inhomogeneous broadening* contributions.
- The combined *homogeneous and inhomogeneous BW* of EDFAs:  $\sim 30$  nm.



***Amplification factor:***

- Define as:

$$G = P_{out}/P_{in}$$

$P_{out}$  is the *amplifier output power* and  $P_{in}$  the *input power* of a CW input signal.

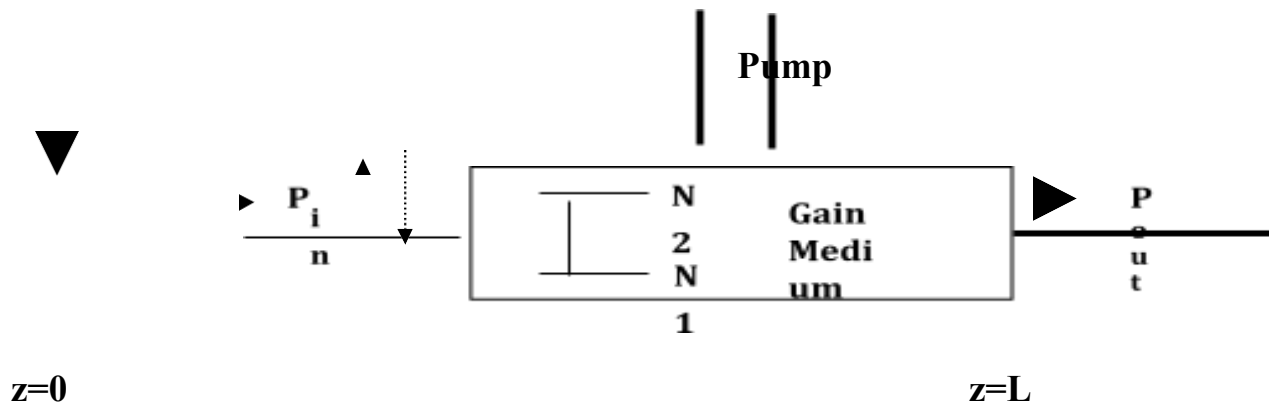

- From the previous discussion of the laser the gain in optical power per length of gain medium ( $z$ ) with gain  $g$  is

$$dP = gP dz$$

- Integrating over a length  $z$  of amplifier medium gives the resultant optical power

$$P(z) = P(0) \exp(gz) .$$

The amplification factor after a length  $L$  of OAM (optical amplifier medium) is

$$G(\mathbf{c}) = \exp[g(\mathbf{c})L]$$

Both  $g(\mathbf{m})$  and  $G(\mathbf{m})$  are a maximum when the frequency is at resonance  $\mathbf{c} = \mathbf{c}_o$  and decrease when the frequency is detuned from resonance.

However the *amplifier factor* ( $G$ ) decreases much faster than the *gain coefficient* ( $g$ ).

- The *amplifier BW*  $Av_A$  is defined as the *FWHM* of  $G(\mathbf{c})$

$$Av_A = Av_g \left\{ \ln 2 \right\}^{0.5} \left( \frac{1}{g} \left| \ln(G_0/2) \right| \right)$$

where  $Av_g$  is the gain BW, and  $G_0 = \exp(g_o L)$ .

- The *amplifier BW* is smaller than the *gain BW*. The difference depends on the *amplifier gain* characteristics.

$$\text{If } G_0 = 10, \quad Av_A = 0.656 Av_g$$

**Gain Saturation:**

- Since  $g(\omega)$  depends on the incident optical power when  $P = P_s$ , *G will start to decrease with an increase in optical power P.*
- Assume that the incident frequency is tuned for peak gain ( $m = m_0$ )

$$\frac{dP}{dz} = \frac{g_0 P}{1 + \frac{P}{P_s}}$$

- With the conditions  $P(0) = P_{inc}$  and  $P(L) = P_{out} = GP_{inc}$  **the large signal amplifier gain** becomes

$$G = G_0 \exp\left\{ \frac{G - 1 P_{out}}{G P_s} \right\}$$

- This expression shows how the amplifier gain decreases when  $P_{out} = P_s$ .

**Output saturation power** ÷ the optical power at which  $G$  is reduced to  $G_0/2$  (3 dB)

$$= \frac{G_0 \ln 2}{G}$$

$P_{out}$

$$= \frac{G_0 \ln 2}{G}$$

- Typically  $G_0 = 1000$  (30 dB),

$P$

$s_{out}$

$$= (\ln 2)P_s$$

$$= 0.69P_s.$$

**Amplifier Noise:**

- *Spontaneous emission* in the amplifier will *degrade the SNR* by adding to the noise during the amplification process.
- SNR degradation is quantified through the amplifier noise figure  $F_n$

$$F_n = \frac{(S/N)_{in}}{(S/N)_{out}}$$

where the SNR is based on the electrical power after converting the optical signal to an electrical current. Therefore  $F_n$  is referenced to the detection process and depends on parameters such as detector bandwidth ( $B_e$ ) and thermal and shot noise.

- Consider a simple case with an ideal detector with performance limited by *shot noise*.
- The amplifier has an *amplification factor*  $G$  ( $P_{out} = G P_{in}$ ).
- SNR of the input signal:

$$SNR_{in} = \frac{(RP_{in})^2}{2q(RP_{in})B_e} = \frac{P_{in}}{2h\nu B_e} \quad I^2$$

$$O_s^2 = 2q(RP_{in})B_e$$

- The spontaneous emission contribution is amplified along with the signal. The *Spectral density* of the *spontaneous emission induced noise* is nearly constant

(white noise) and can be expressed as:

$$S_{sp}(\nu) = (G - 1)n_{sp}h\nu$$

- *Spontaneous emission population inversion factor  $n_{sp}$  is given by:*

$$n_{sp} = \frac{N_2}{N_2 - N_1}$$

$N_2$  and  $N_1$  are the population densities for the excited and ground states of the amplifying medium.

- Alternatively can express the *spontaneous emission power* within the receiver bandwidth  $B_e$  as:

$$P_{sp} = 2S_{sp} B_e$$

- *Spontaneous emission* adds *fluctuations to the amplified power* and is converted to *current fluctuations* at the *detector output*.
- Major contribution to receiver noise results from coherent interference (beating) between the spontaneous emission with the signal. This results in a noise current given by

$$\Delta I = 2R(GP_{in} P_{sp})^{1/2} \cos\delta$$

- The variance in the photocurrent after the signal is passed through the amplifier is

$$\sigma^2 = 4(RGP_{in}) \cdot (RS_{sp}) B_e$$

where  $\cos^2 \theta$  is replaced with its average value of  $1/2$ . (Note that this relation assumes several idealizations on the detection process i.e. other noise sources are negligible.)

- The SNR of the amplified signal becomes

$$SNR_{out} = \frac{(RGP_{in})^2}{4S_{sp} B_e} = \frac{GP_{in}}{2S_{sp} B_e}$$

and the amplifier noise figure is

$$F_n = 2n_{sp}(G-1)/G = 2n_{sp}$$

- For most amplifiers  $F_n > 3$  dB and can be 6-8 dB.



- Characteristic plot of gain and noise figure for an erbium doped fiber amplifier pumped  $\sim 30$  mW at 980 nm.

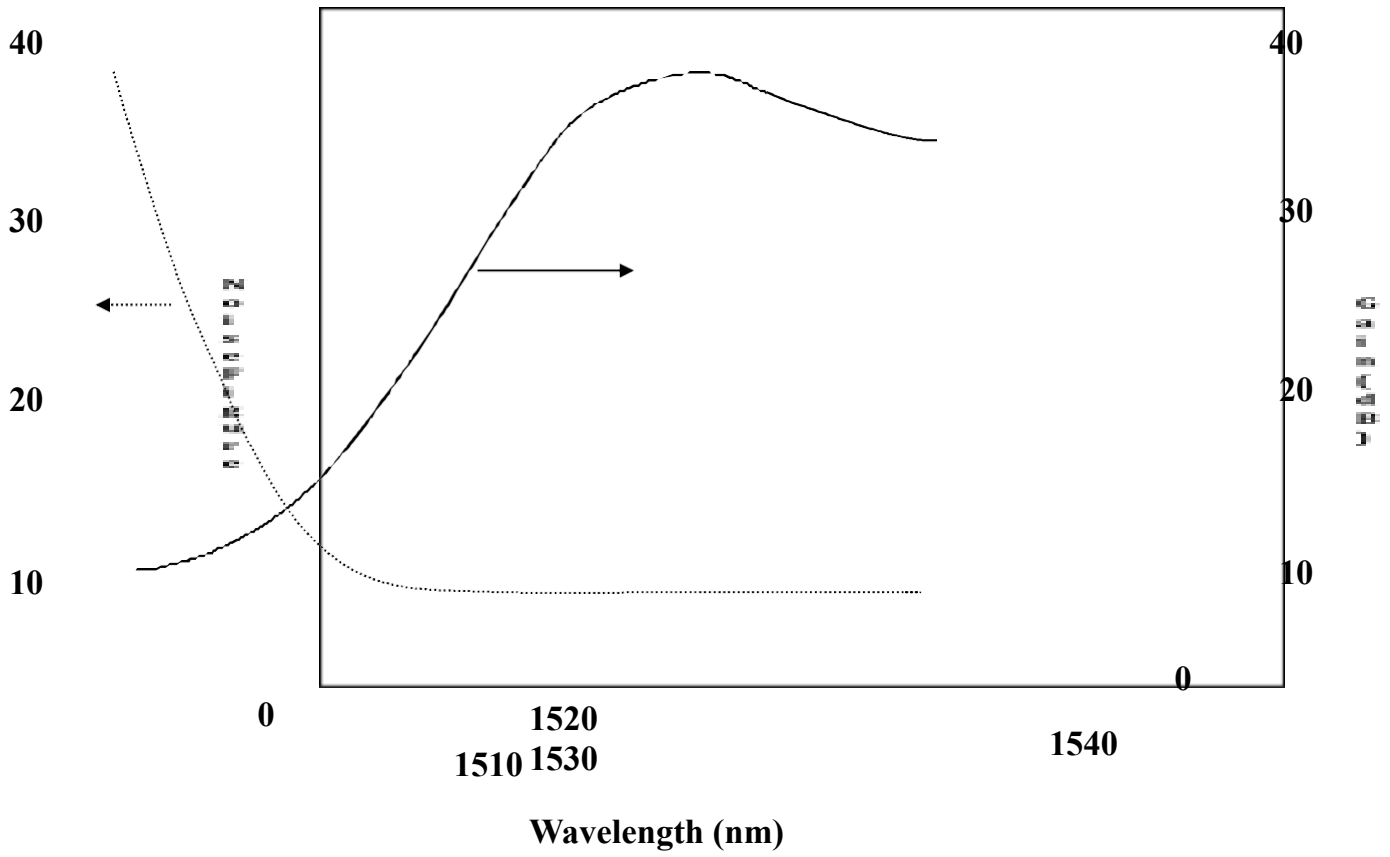

## EDFA Gain Equalization

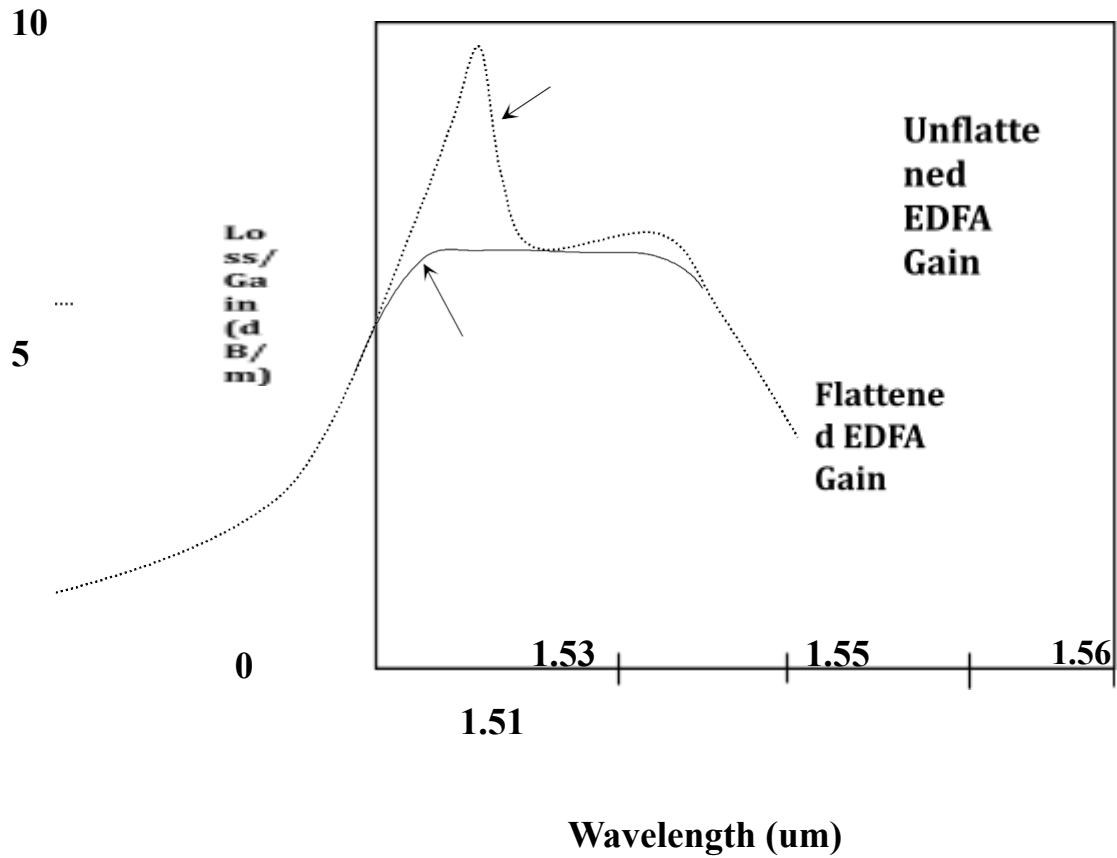

- Gain equalization can be accomplished in several ways:
  - a. Thin film filters
  - b. Long period fiber gratings
  - c. Chirped fiber Bragg gratings

**Raman Scattering, Stimulated Raman Scattering, and Raman Amplifiers:**

- Raman scattering is an *elastic scattering mechanism*. Does not require a population inversion.
- A photon with energy  $h\nu_1$  traveling through a material can excite a *vibrational transition* of the material forming an *optical phonon* with energy  $h\nu_p$  and a photon with slightly reduced energy  $h\nu_2$  given by

$$\nu_2 = \nu_1 - \nu_p$$

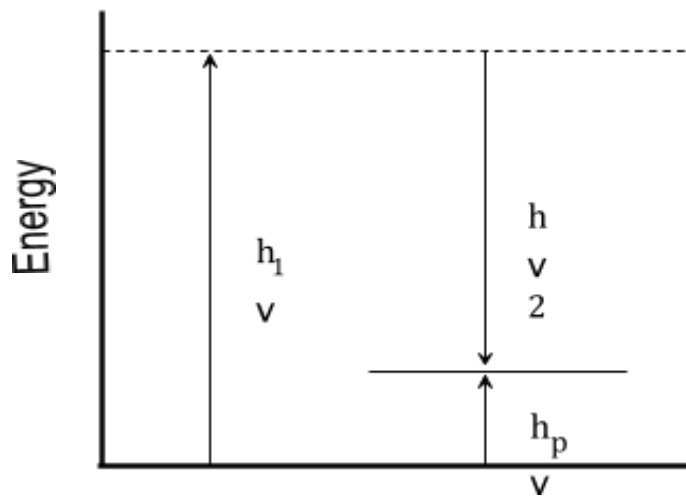

- Molecule is raised to a new *vibrational state* and the energy of the photon is reduced.
- There is a large difference between the photon and phonon energies.
- Raman scattering is *weak effect*. It occurs through a slight modulation of the refractive index through molecular vibrations of the material.
- Can derive the effect through a discussion of polarizability of a material.

- The electric field induces a *dipole moment of the molecule*

$$p = qx$$

or

$$p = \alpha E$$

where  $\alpha$  is the complex polarizability of the molecule.

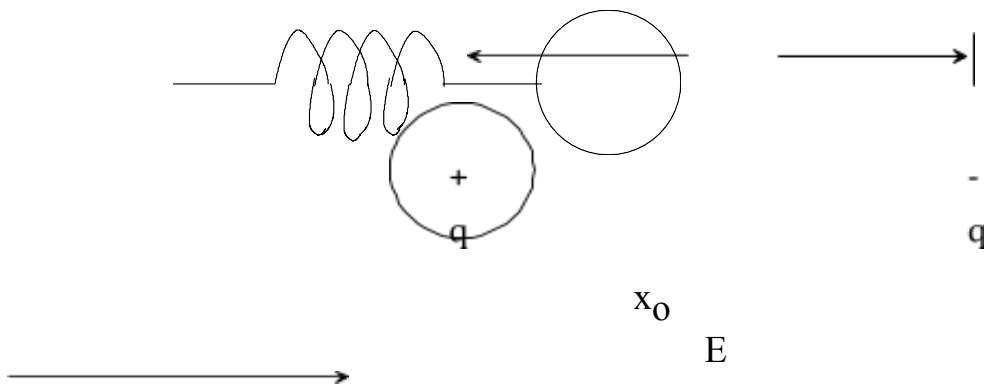

- The *bulk polarizability* of a material is expressed as

$$P = c \sum_{i=1}^N \alpha_i E$$

with  $\sum_{i=1}^N \alpha_i$

the linear susceptibility of the material.

- Response of  $\alpha$  to an incident *harmonic electric field*:

$$\alpha(x) = \alpha_0 + \frac{\partial \alpha}{\partial x} \bigg|_x 6x$$

$6x$  is the displacement from the *equilibrium molecular length*  $x_0$

$$6x(t) = 6x_0 e^{\pm j\omega_p t}$$

$$\begin{aligned}
 p(t) &= \alpha(t) E(t) e^{\pm j\mathbf{c}t} \\
 &= \left( \alpha_0 + \alpha_1 e^{j\mathbf{c}_0 t} + \alpha_2 e^{-j\mathbf{c}_0 t} \right) E_0 e^{j\mathbf{c}t} \\
 &= \alpha_0 E_0 e^{j\mathbf{c}t} + \alpha_1 E_0 e^{j(\mathbf{c} + \mathbf{c}_0)t} + \alpha_2 E_0 e^{j(\mathbf{c} - \mathbf{c}_0)t}
 \end{aligned}$$

o o

6 x  
o o x o

- There are two frequency components: a)  $\mathbf{c}_1$  ; b)  $\mathbf{c}_1 \pm \mathbf{c}_p$
- The second component is *nonlinear* → the output frequency is different from the input frequency.

### Stokes

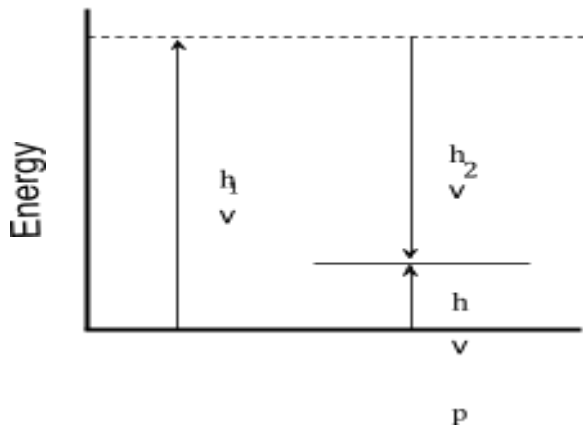

### Anti-Stokes

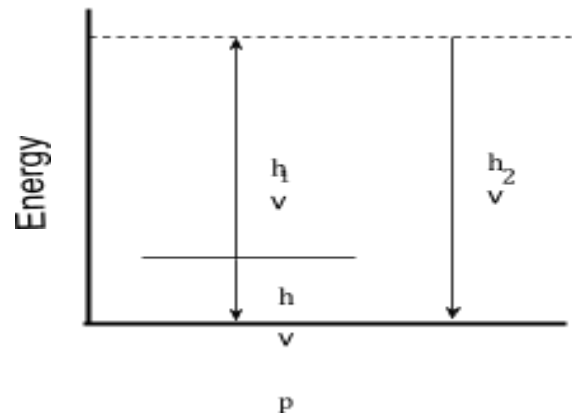

- Scattered light with lower energy ( $\nu_2 < \nu_1$ ) → *Stokes Scattering*.
- Scattered light with higher energy ( $\nu_2 > \nu_1$ ) → *Anti-Stokes Scattering*.
- Stokes scattering typically dominates due to greater population of the ground state relative to the vibrational state when the system is in thermal equilibrium.
- *At low illumination levels* the Raman process results in low scattering levels.

- The molecules contributing to the process are vibrating independently and the scattered light is non-directional. *Spontaneous Raman Scattering.*

- At *higher intensity levels* the generated photons begin to act *in phase* or *coherently* – i.e. the molecules oscillate as an array of vibrating oscillators. This gives rise to Stimulated Raman Scattering (SRS).
- SRS can be a problem but it can also be used as a signal amplification process.
- On the negative side it contributes to *dispersion* and places an *operational limit on the amount of power* that can be transmitted through a fiber.
- The Stokes wave is amplified as it propagates through the medium

$$dI_2 = G_r I_1 I_2 dz$$

---

$$dz$$

$I_2$  is the intensity of the *Stokes shifted light* ( $\omega_s = \omega_p - \omega_{vib}$ );  $I_1$  is the intensity of the *pump beam* ( $\omega_p$ ); and  $G_r$  is the *Raman gain* term that includes material factors such as  $6\alpha / 6x$  and varies as  $1/\lambda^2$ .

- For  $I_2 \ll I_1$  and cases where the pump beam is not significantly depleted:

$$I_2(z) = I_2(0) e^{G_r I_1 z}$$

Properties of Raman Amplifiers:

- The peak resonance in silica fibers occurs about 13 THz from the pump wavelength. At 1550 nm this corresponds to a shift of about 100 nm.

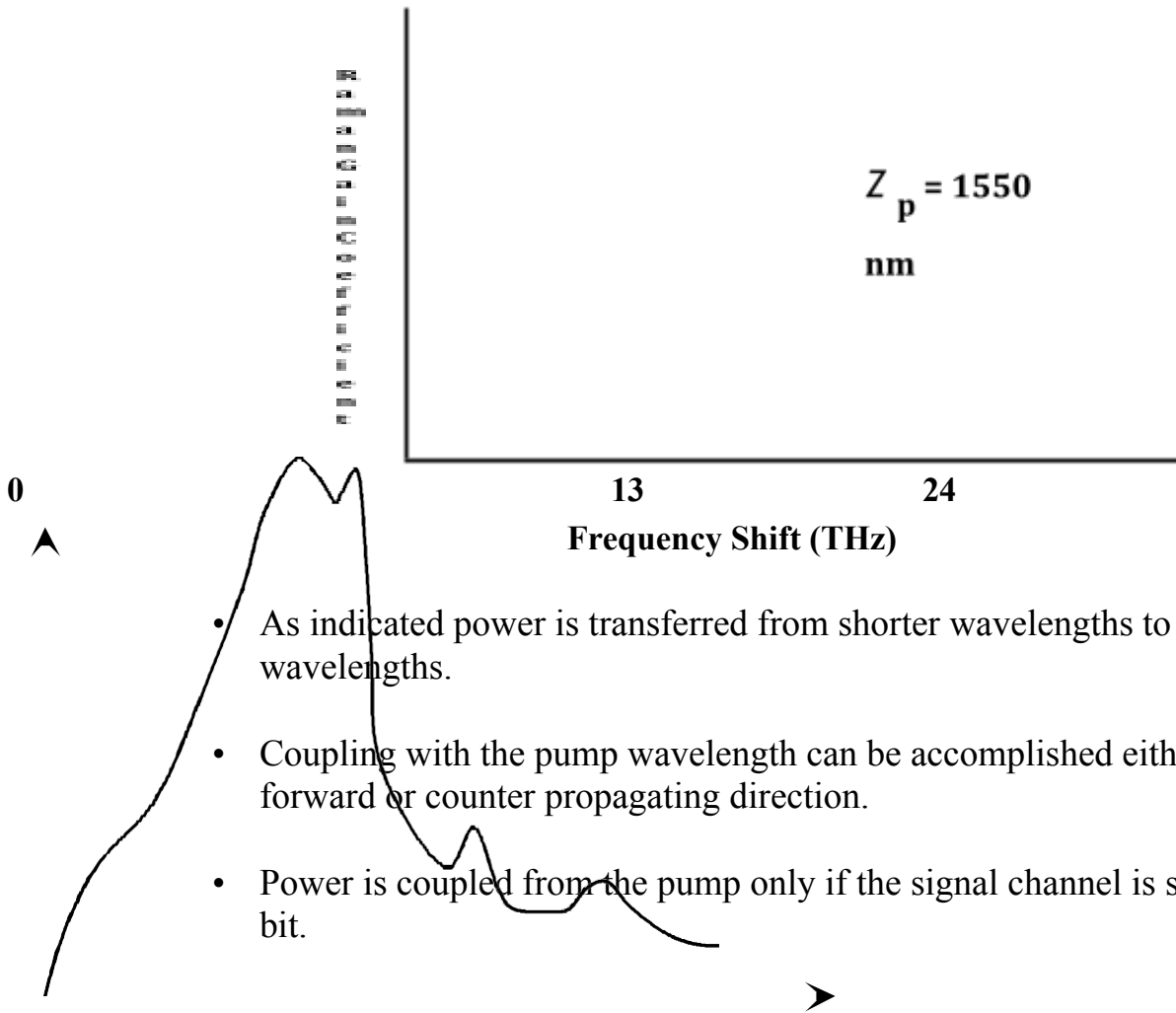

- As indicated power is transferred from shorter wavelengths to longer wavelengths.
- Coupling with the pump wavelength can be accomplished either in the forward or counter propagating direction.
- Power is coupled from the pump only if the signal channel is sending a 1 bit.



**Pump Arrangement to Extend the Range for Stimulated Raman Amplification:**

- An array of laser diodes can be used to provide the Raman pump. The beams are combined and then coupled to the transmission fiber. The pump beams can counter propagate to the direction of the signal beams.

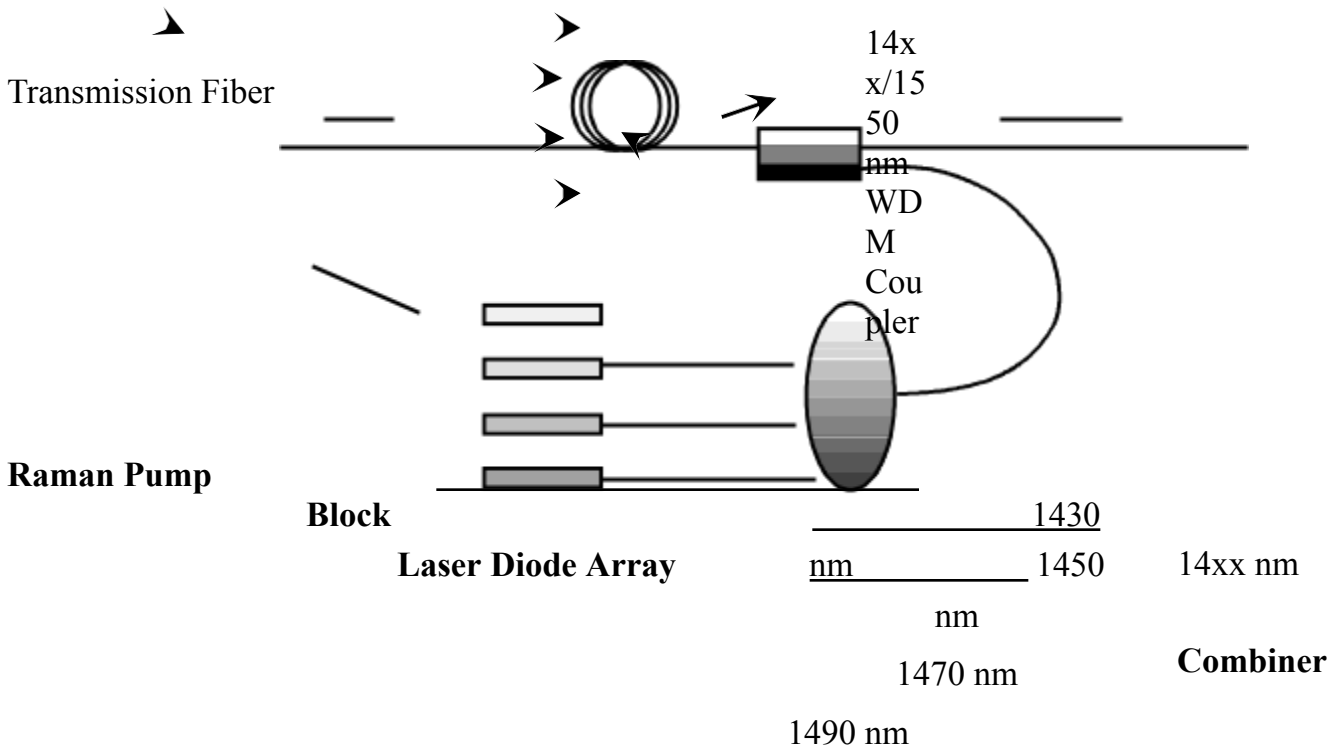

**Difficulties with Raman Amplifiers:**

- The Pump and amplified signals are at *different wavelengths*. Therefore the signal and the pump pulses will separate due to dispersion (*waveguide dispersion*) after a certain propagation distance. The difference in *propagation time* is given by:

$$\Delta t = \left( \frac{L}{c} \right) \beta^2 d^2 n / d\beta^2 \left( \omega_p / \omega_s \right)$$

L is the fiber length.

- A 1 psec pump pulse at 600 nm separates from a 1 psec Stokes pulse in ~ 30 cm.
- A *second problem* is that the *pump power decreases* along the fiber length due to linear absorption and scattering – Raman gain is greater at the input end.
- A final problem results from *amplifying spontaneous Raman photons*. This occurs when the pump power is increased to offset attenuation losses and spontaneous Raman photons are coupled into the guided mode all along the length of the fiber. This increases noise.
- Upper limit on the power into a communications signal from SRS amplification can be defined as the *point at which the Stokes power  $P_r$  equals the signal power  $P_{sig}$* .

$$16m \omega^2 P = \frac{G_r L_{eff}}{1 - e^{-\alpha L}}$$

$$1 - e^{-\alpha L}$$

$$\frac{L_{eff}}{\alpha} =$$

**Example:**

$$\beta_p = 1.55 \mu m \quad = 80 \mu m^2$$

$$w_o = 5 \mu m \rightarrow A_{mode}$$

$$\alpha_{linear} = 0.2 dB / km \rightarrow L_{eff} = 20 km \rightarrow \underline{700 mW}$$

$$G_r = 9 \times 10^{-12} m / W$$

QUITE LARGE compared to normal optical signal powers ( $\sim 1$  mW).